

Trigonometry can be used to model the flight of a baseball. Given the angle at which the ball leaves the bat and the initial velocity, you can determine the distance the ball will travel.

Al Bello/Getty Images



# 5

## Analytic Trigonometry

### What You Should Learn

In this chapter, you will learn how to:

- 5.1 Using Fundamental Identities
  - 5.2 Verifying Trigonometric Identities
  - 5.3 Solving Trigonometric Equations
  - 5.4 Sum and Difference Formulas
  - 5.5 Multiple-Angle and Product-to-Sum Formulas
- Use fundamental trigonometric identities to evaluate trigonometric functions and simplify trigonometric expressions.
  - Verify trigonometric identities.
  - Use standard algebraic techniques and inverse trigonometric functions to solve trigonometric equations.
  - Use sum and difference formulas, multiple-angle formulas, power-reducing formulas, half-angle formulas, and product-to-sum formulas to rewrite and evaluate trigonometric functions.

## 5.1 Using Fundamental Identities

### Introduction

In Chapter 4, you studied the basic definitions, properties, graphs, and applications of the individual trigonometric functions. In this chapter, you will learn how to use the fundamental identities to do the following.

1. Evaluate trigonometric functions.
2. Simplify trigonometric expressions.
3. Develop additional trigonometric identities.
4. Solve trigonometric equations.

#### Fundamental Trigonometric Identities

##### Reciprocal Identities

$$\sin u = \frac{1}{\csc u} \quad \cos u = \frac{1}{\sec u} \quad \tan u = \frac{1}{\cot u}$$

$$\csc u = \frac{1}{\sin u} \quad \sec u = \frac{1}{\cos u} \quad \cot u = \frac{1}{\tan u}$$

##### Quotient Identities

$$\tan u = \frac{\sin u}{\cos u} \quad \cot u = \frac{\cos u}{\sin u}$$

##### Pythagorean Identities

$$\sin^2 u + \cos^2 u = 1 \quad 1 + \tan^2 u = \sec^2 u \quad 1 + \cot^2 u = \csc^2 u$$

##### Cofunction Identities

$$\sin\left(\frac{\pi}{2} - u\right) = \cos u \quad \cos\left(\frac{\pi}{2} - u\right) = \sin u$$

$$\tan\left(\frac{\pi}{2} - u\right) = \cot u \quad \cot\left(\frac{\pi}{2} - u\right) = \tan u$$

$$\sec\left(\frac{\pi}{2} - u\right) = \csc u \quad \csc\left(\frac{\pi}{2} - u\right) = \sec u$$

##### Even/Odd Identities

$$\sin(-u) = -\sin u \quad \cos(-u) = \cos u \quad \tan(-u) = -\tan u$$

$$\csc(-u) = -\csc u \quad \sec(-u) = \sec u \quad \cot(-u) = -\cot u$$

### Using the Fundamental Identities

One common use of trigonometric identities is to use given values of trigonometric functions to evaluate other trigonometric functions.

#### What you should learn

- Recognize and write the fundamental trigonometric identities.
- Use the fundamental trigonometric identities to evaluate trigonometric functions, simplify trigonometric expressions, and rewrite trigonometric expressions.

#### Why you should learn it

The fundamental trigonometric identities can be used to simplify trigonometric expressions. For instance, Exercise 97 on page 347 shows you how trigonometric identities can be used to simplify an expression for the rate of change of a function, a concept used in calculus.

#### STUDY TIP

Pythagorean identities are sometimes used in radical form such as

$$\sin u = \pm \sqrt{1 - \cos^2 u}$$

or

$$\tan u = \pm \sqrt{\sec^2 u - 1}$$

where the sign depends on the choice of  $u$ .

**Example 1** Using Identities to Evaluate a Function

Use the values  $\sec u = -\frac{3}{2}$  and  $\tan u > 0$  to find the values of all six trigonometric functions.

**Solution**

Using a reciprocal identity, you have

$$\cos u = \frac{1}{\sec u} = \frac{1}{-3/2} = -\frac{2}{3}$$

Using a Pythagorean identity, you have

$$\sin^2 u = 1 - \cos^2 u$$

Pythagorean identity

$$= 1 - \left(-\frac{2}{3}\right)^2$$

Substitute  $-\frac{2}{3}$  for  $\cos u$ .

$$= 1 - \frac{4}{9} = \frac{5}{9}$$

Simplify.

Because  $\sec u < 0$  and  $\tan u > 0$ , it follows that  $u$  lies in Quadrant III. Moreover, because  $\sin u$  is negative when  $u$  is in Quadrant III, you can choose the negative root and obtain  $\sin u = -\sqrt{5}/3$ . Now, knowing the values of the sine and cosine, you can find the values of all six trigonometric functions.

$$\sin u = -\frac{\sqrt{5}}{3}$$

$$\csc u = \frac{1}{\sin u} = -\frac{3}{\sqrt{5}} = -\frac{3\sqrt{5}}{5}$$

$$\cos u = -\frac{2}{3}$$

$$\sec u = \frac{1}{\cos u} = -\frac{3}{2}$$

$$\tan u = \frac{\sin u}{\cos u} = \frac{-\sqrt{5}/3}{-2/3} = \frac{\sqrt{5}}{2}$$

$$\cot u = \frac{1}{\tan u} = \frac{2}{\sqrt{5}} = \frac{2\sqrt{5}}{5}$$

 **Checkpoint** Now try Exercise 11.

**Example 2** Simplifying a Trigonometric Expression

Simplify  $\sin x \cos^2 x - \sin x$ .

**Solution**

First factor out a common monomial factor and then use a fundamental identity.

$$\sin x \cos^2 x - \sin x = \sin x(\cos^2 x - 1)$$

Factor out monomial factor.

$$= -\sin x(1 - \cos^2 x)$$

Distributive Property

$$= -\sin x(\sin^2 x)$$

Pythagorean identity

$$= -\sin^3 x$$

Multiply.

 **Checkpoint** Now try Exercise 29.

**TECHNOLOGY TIP**

You can use a graphing utility to check the result of Example 2. To do this, enter  $y_1$  and  $y_2$  as shown below.

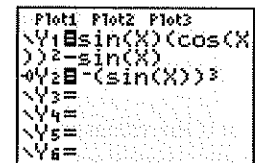

Select the *line* style for  $y_1$  and the *path* style for  $y_2$  (see figure above). The *path* style, denoted by  $\rightarrow$ , traces the leading edge of the graph and draws a path. Now, graph both equations in the same viewing window, as shown below. The two graphs *appear* to coincide, so the expressions *appear* to be equivalent. Remember that in order to be certain that two expressions are equivalent, you need to show their equivalence algebraically, as in Example 2.

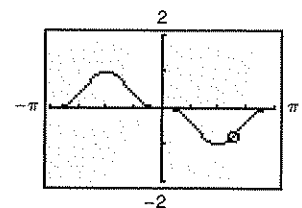

**Example 3** Verifying a Trigonometric Identity

Determine whether the equation appears to be an identity.

$$\cos 3x \stackrel{?}{=} 4 \cos^3 x - 3 \cos x$$

**Numerical Solution**

Use the *table* feature of a graphing utility set in *radian* mode to create a table that shows the values of  $y_1 = \cos 3x$  and  $y_2 = 4 \cos^3 x - 3 \cos x$  for different values of  $x$ , as shown in Figure 5.1. The values of  $y_1$  and  $y_2$  appear to be identical, so  $\cos 3x = 4 \cos^3 x - 3 \cos x$  appears to be an identity.

X	Y <sub>1</sub>	Y <sub>2</sub>
-5	.07074	.07074
-.25	.73169	.73169
0	1	1
.25	.73169	.73169
.5	.07074	.07074
.75	-.6282	-.6282
1	-.99	-.99

Figure 5.1

Note that if the values of  $y_1$  and  $y_2$  were not identical, then the equation would not be an identity.

 **Checkpoint** Now try Exercise 39.

**Graphical Solution**

Use a graphing utility set in *radian* mode to graph  $y_1 = \cos 3x$  and  $y_2 = 4 \cos^3 x - 3 \cos x$  in the same viewing window, as shown in Figure 5.2. (Select the *line* style for  $y_1$  and the *path* style for  $y_2$ .) Because the graphs appear to coincide,  $\cos 3x = 4 \cos^3 x - 3 \cos x$  appears to be an identity.

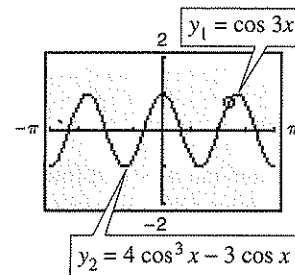

Figure 5.2

Note that if the graphs of  $y_1$  and  $y_2$  did not coincide, then the equation would not be an identity.

**Example 4** Verifying a Trigonometric Identity

Verify the identity  $\frac{\sin \theta}{1 + \cos \theta} + \frac{\cos \theta}{\sin \theta} = \csc \theta$ .

**Algebraic Solution**

$$\begin{aligned} \frac{\sin \theta}{1 + \cos \theta} + \frac{\cos \theta}{\sin \theta} &= \frac{(\sin \theta)(\sin \theta) + (\cos \theta)(1 + \cos \theta)}{(1 + \cos \theta)(\sin \theta)} \\ &= \frac{\sin^2 \theta + \cos^2 \theta + \cos \theta}{(1 + \cos \theta)(\sin \theta)} && \text{Multiply.} \\ &= \frac{1 + \cos \theta}{(1 + \cos \theta)(\sin \theta)} && \text{Pythagorean identity} \\ &= \csc \theta && \text{Divide out common factor and use reciprocal identity.} \end{aligned}$$

Notice how the identity is verified. You start with the left side of the equation (the more complicated side) and use the fundamental trigonometric identities to simplify it until you obtain the right side.

 **Checkpoint** Now try Exercise 45.

**Graphical Solution**

Use a graphing utility set in *radian* and *dot* modes to graph  $y_1$  and  $y_2$  in the same viewing window, as shown in Figure 5.3. Because the graphs appear to coincide, this equation appears to be an identity.

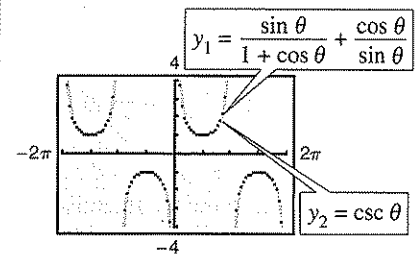

Figure 5.3

When factoring trigonometric expressions, it is helpful to find a polynomial form that fits the expression, as shown in Example 5.

### Example 5 Factoring Trigonometric Expressions

Factor (a)  $\sec^2 \theta - 1$  and (b)  $4 \tan^2 \theta + \tan \theta - 3$ .

#### Solution

a. Here the expression is a difference of two squares, which factors as

$$\sec^2 \theta - 1 = (\sec \theta - 1)(\sec \theta + 1).$$

b. This expression has the polynomial form  $ax^2 + bx + c$  and it factors as

$$4 \tan^2 \theta + \tan \theta - 3 = (4 \tan \theta - 3)(\tan \theta + 1).$$

 **Checkpoint** Now try Exercise 51.

On occasion, factoring or simplifying can best be done by first rewriting the expression in terms of just *one* trigonometric function or in terms of *sine or cosine alone*. These strategies are illustrated in Examples 6 and 7.

### Example 6 Factoring a Trigonometric Expression

Factor  $\csc^2 x - \cot x - 3$ .

#### Solution

Use the identity  $\csc^2 x = 1 + \cot^2 x$  to rewrite the expression in terms of the cotangent.

$$\begin{aligned} \csc^2 x - \cot x - 3 &= (1 + \cot^2 x) - \cot x - 3 && \text{Pythagorean identity} \\ &= \cot^2 x - \cot x - 2 && \text{Combine like terms.} \\ &= (\cot x - 2)(\cot x + 1) && \text{Factor.} \end{aligned}$$

 **Checkpoint** Now try Exercise 57.

### Example 7 Simplifying a Trigonometric Expression

Simplify  $\sin t + \cot t \cos t$ .

#### Solution

Begin by rewriting  $\cot t$  in terms of sine and cosine.

$$\begin{aligned} \sin t + \cot t \cos t &= \sin t + \left( \frac{\cos t}{\sin t} \right) \cos t && \text{Quotient identity} \\ &= \frac{\sin^2 t + \cos^2 t}{\sin t} && \text{Add fractions.} \\ &= \frac{1}{\sin t} = \csc t && \text{Pythagorean identity and} \\ &&& \text{reciprocal identity} \end{aligned}$$

 **Checkpoint** Now try Exercise 67.

## 5.1 Exercises

## Vocabulary Check

Fill in the blank to complete the trigonometric identity.

1.  $\frac{1}{\cos u} = \underline{\hspace{2cm}}$

2.  $\frac{1}{\cot u} = \underline{\hspace{2cm}}$

3.  $\frac{\cos u}{\sin u} = \underline{\hspace{2cm}}$

4.  $\frac{1}{\sin u} = \underline{\hspace{2cm}}$

5.  $1 + \underline{\hspace{2cm}} = \csc^2 u$

6.  $1 + \tan^2 u = \underline{\hspace{2cm}}$

7.  $\cos\left(\frac{\pi}{2} - u\right) = \underline{\hspace{2cm}}$

8.  $\sec\left(\frac{\pi}{2} - u\right) = \underline{\hspace{2cm}}$

9.  $\sin(-u) = \underline{\hspace{2cm}}$

10.  $\cos(-u) = \underline{\hspace{2cm}}$

In Exercises 1–14, use the given values to evaluate (if possible) all six trigonometric functions.

1.  $\sin x = \frac{\sqrt{3}}{2}, \cos x = \frac{1}{2}$

2.  $\csc \theta = 2, \tan \theta = \frac{\sqrt{3}}{3}$

3.  $\sec \theta = \sqrt{2}, \sin \theta = -\frac{\sqrt{2}}{2}$

4.  $\tan x = \frac{\sqrt{3}}{3}, \cos x = -\frac{\sqrt{3}}{2}$

5.  $\tan x = \frac{7}{24}, \sec x = -\frac{25}{24}$

6.  $\cot \phi = -5, \sin \phi = \frac{\sqrt{26}}{26}$

7.  $\sec \phi = -\frac{13}{12}, \sin \phi = \frac{5}{13}$

8.  $\cos\left(\frac{\pi}{2} - x\right) = \frac{3}{5}, \cos x = \frac{4}{5}$

9.  $\sin(-x) = -\frac{2}{3}, \tan x = -\frac{2\sqrt{5}}{5}$

10.  $\csc(-x) = -5, \cos x = \frac{\sqrt{24}}{5}$

11.  $\tan \theta = 2, \sin \theta < 0$

12.  $\sec \theta = -5, \tan \theta < 0$

13.  $\csc \theta$  is undefined,  $\cos \theta < 0$

14.  $\tan \theta$  is undefined,  $\sin \theta > 0$

In Exercises 15–20, match the trigonometric expression with one of the following.

(a)  $\sec x$  (b)  $-1$  (c)  $\cot x$

(d)  $1$  (e)  $-\tan x$  (f)  $\sin x$

15.  $\sec x \cos x$

16.  $\tan x \csc x$

17.  $\cot^2 x - \csc^2 x$

18.  $(1 - \cos^2 x)(\csc x)$

19.  $\frac{\sin(-x)}{\cos(-x)}$

20.  $\frac{\sin[(\pi/2) - x]}{\cos[(\pi/2) - x]}$

In Exercises 21–26, match the trigonometric expression with one of the following.

(a)  $\csc x$  (b)  $\tan x$  (c)  $\sin^2 x$

(d)  $\sin x \tan x$  (e)  $\sec^2 x$  (f)  $\sec^2 x + \tan^2 x$

21.  $\sin x \sec x$

22.  $\cos^2 x(\sec^2 x - 1)$

23.  $\sec^4 x - \tan^4 x$

24.  $\cot x \sec x$

25.  $\frac{\sec^2 x - 1}{\sin^2 x}$

26.  $\frac{\cos^2[(\pi/2) - x]}{\cos x}$

In Exercises 27–38, use the fundamental identities to simplify the expression. Use the *table* feature of a graphing utility to check your result numerically.

27.  $\cot x \sin x$

28.  $\cos \beta \tan \beta$

29.  $\sin \phi(\csc \phi - \sin \phi)$

30.  $\sec^2 x(1 - \sin^2 x)$

31.  $\frac{\cot x}{\csc x}$

32.  $\frac{\sec \theta}{\csc \theta}$

33.  $\sec \alpha \cdot \frac{\sin \alpha}{\tan \alpha}$

34.  $\frac{\tan^2 \theta}{\sec^2 \theta}$

35.  $\sin\left(\frac{\pi}{2} - x\right) \csc x$

36.  $\cot\left(\frac{\pi}{2} - x\right) \cos x$

37.  $\frac{\cos^2 y}{1 - \sin y}$

38.  $\frac{1}{\tan^2 x + 1}$

In Exercises 39–44, verify the identity algebraically. Use the *table* feature of a graphing utility to check your result numerically.

39.  $\sin \theta + \cos \theta \cot \theta = \csc \theta$

40.  $(\sec \theta - \tan \theta)(\csc \theta + 1) = \cot \theta$

41.  $\frac{\cos \theta}{1 - \sin \theta} = \sec \theta + \tan \theta$

42.  $\frac{1 + \csc \theta}{\cot \theta + \cos \theta} = \sec \theta$

43.  $\frac{1 + \cos \theta}{\sin \theta} + \frac{\sin \theta}{1 + \cos \theta} = 2 \csc \theta$

44.  $\frac{\sin \theta + \cos \theta}{\sin \theta} - \frac{\cos \theta - \sin \theta}{\cos \theta} = \sec \theta \csc \theta$

In Exercises 45–50, verify the identity algebraically. Use a graphing utility to check your result graphically.

45.  $\csc \theta \tan \theta = \sec \theta$

46.  $\cos \theta \sec \theta - \cos^2 \theta = \sin^2 \theta$

47.  $1 - \frac{\sin^2 \theta}{1 - \cos \theta} = -\cos \theta$

48.  $\frac{\tan \theta}{1 + \sec \theta} + \frac{1 + \sec \theta}{\tan \theta} = 2 \csc \theta$

49.  $\frac{\cot(-\theta)}{\csc \theta} = -\cos \theta$

50.  $\frac{\csc\left(\frac{\pi}{2} - \theta\right)}{\tan(-\theta)} = \csc \theta$

In Exercises 51–60, factor the expression and use the fundamental identities to simplify. Use a graphing utility to check your result graphically.

51.  $\cot^2 x - \cot^2 x \cos^2 x$

52.  $\sec^2 x \tan^2 x + \sec^2 x$

53.  $\frac{\cos^2 x - 4}{\cos x - 2}$

54.  $\frac{\csc^2 x - 1}{\csc x - 1}$

55.  $\tan^4 x + 2 \tan^2 x + 1$

56.  $1 - 2 \sin^2 x + \sin^4 x$

57.  $\sin^4 x - \cos^4 x$

58.  $\sec^4 x - \tan^4 x$

59.  $\csc^3 x - \csc^2 x - \csc x + 1$

60.  $\sec^3 x - \sec^2 x - \sec x + 1$

In Exercises 61–64, perform the multiplication and use the fundamental identities to simplify.

61.  $(\sin x + \cos x)^2$

62.  $(\cot x + \csc x)(\cot x - \csc x)$

63.  $(\sec x + 1)(\sec x - 1)$

64.  $(3 - 3 \sin x)(3 + 3 \sin x)$

In Exercises 65–68, perform the addition or subtraction and use the fundamental identities to simplify.

65.  $\frac{1}{1 + \cos x} + \frac{1}{1 - \cos x}$

66.  $\frac{1}{\sec x + 1} - \frac{1}{\sec x - 1}$

67.  $\tan x - \frac{\sec^2 x}{\tan x}$

68.  $\frac{\cos x}{1 + \sin x} + \frac{1 + \sin x}{\cos x}$

In Exercises 69–72, rewrite the expression so that it is not in fractional form.

69.  $\frac{\sin^2 y}{1 - \cos y}$

70.  $\frac{5}{\tan x + \sec x}$

71.  $\frac{3}{\sec x - \tan x}$

72.  $\frac{\tan^2 x}{\csc x + 1}$

**Numerical and Graphical Analysis** In Exercises 73–76, use a graphing utility to complete the table and graph the functions in the same viewing window. Make a conjecture about  $y_1$  and  $y_2$ .

$x$	0.2	0.4	0.6	0.8	1.0	1.2	1.4
$y_1$							
$y_2$							

73.  $y_1 = \cos\left(\frac{\pi}{2} - x\right), y_2 = \sin x$

74.  $y_1 = \cos x + \sin x \tan x, y_2 = \sec x$

75.  $y_1 = \frac{\cos x}{1 - \sin x}, y_2 = \frac{1 + \sin x}{\cos x}$

76.  $y_1 = \sec^4 x - \sec^2 x, y_2 = \tan^2 x + \tan^4 x$

In Exercises 77–80, use a graphing utility to determine which of the six trigonometric functions is equal to the expression.

77.  $\cos x \cot x + \sin x$       78.  $\sin x(\cot x + \tan x)$

79.  $\sec x - \frac{\cos x}{1 + \sin x}$

80.  $\frac{1}{2} \left( \frac{1 + \sin \theta}{\cos \theta} + \frac{\cos \theta}{1 + \sin \theta} \right)$

¶ In Exercises 81–84, use the trigonometric substitution to write the algebraic expression as a trigonometric function of  $\theta$ , where  $0 < \theta < \pi/2$ .

81.  $\sqrt{25 - x^2}$ ,  $x = 5 \sin \theta$

82.  $\sqrt{64 - 16x^2}$ ,  $x = 2 \cos \theta$

83.  $\sqrt{x^2 - 9}$ ,  $x = 3 \sec \theta$

84.  $\sqrt{x^2 + 100}$ ,  $x = 10 \tan \theta$

In Exercises 85–88, use a graphing utility to solve the equation for  $\theta$ , where  $0 \leq \theta < 2\pi$ .

85.  $\sin \theta = \sqrt{1 - \cos^2 \theta}$

86.  $\cos \theta = -\sqrt{1 - \sin^2 \theta}$

87.  $\sec \theta = \sqrt{1 + \tan^2 \theta}$

88.  $\tan \theta = \sqrt{\sec^2 \theta - 1}$

In Exercises 89–92, rewrite the expression as a single logarithm and simplify the result.

89.  $\ln|\cos \theta| - \ln|\sin \theta|$       90.  $\ln|\csc \theta| + \ln|\tan \theta|$

91.  $\ln(1 + \sin x) - \ln|\sec x|$

92.  $\ln|\cot t| + \ln(1 + \tan^2 t)$

In Exercises 93–96, use the *table* feature of a graphing utility to demonstrate the identity for each value of  $\theta$ .

93.  $\csc^2 \theta - \cot^2 \theta = 1$ , (a)  $\theta = 132^\circ$  (b)  $\theta = \frac{2\pi}{7}$

94.  $\tan^2 \theta + 1 = \sec^2 \theta$ , (a)  $\theta = 346^\circ$  (b)  $\theta = 3.1$

95.  $\cos\left(\frac{\pi}{2} - \theta\right) = \sin \theta$ , (a)  $\theta = 80^\circ$  (b)  $\theta = 0.8$

96.  $\sin(-\theta) = -\sin \theta$ , (a)  $\theta = 250^\circ$  (b)  $\theta = \frac{1}{2}$

¶ 97. **Rate of Change** The rate of change of the function  $f(x) = -\csc x - \sin x$  is given by the expression  $\csc x \cot x - \cos x$ . Show that this expression can also be written as  $\cos x \cot^2 x$ .

¶ 98. **Rate of Change** The rate of change of the function  $f(x) = \sec x + \cos x$  is given by the expression  $\sec x \tan x - \sin x$ . Show that this expression can also be written as  $\sin x \tan^2 x$ .

### Synthesis

**True or False?** In Exercises 99 and 100, determine whether the statement is true or false. Justify your answer.

99.  $\sin \theta \csc \theta = 1$       100.  $\cos \theta \sec \theta = 1$

In Exercises 101–104, fill in the blanks. (Note:  $x \rightarrow c^+$  indicates that  $x$  approaches  $c$  from the right, and  $x \rightarrow c^-$  indicates that  $x$  approaches  $c$  from the left.)

101. As  $x \rightarrow \frac{\pi^-}{2}$ ,  $\sin x \rightarrow$       and  $\csc x \rightarrow$

102. As  $x \rightarrow 0^+$ ,  $\cos x \rightarrow$       and  $\sec x \rightarrow$

103. As  $x \rightarrow \frac{\pi^-}{2}$ ,  $\tan x \rightarrow$       and  $\cot x \rightarrow$

104. As  $x \rightarrow \pi^+$ ,  $\sin x \rightarrow$       and  $\csc x \rightarrow$

105. Write each of the other trigonometric functions of  $\theta$  in terms of  $\sin \theta$ .

106. Write each of the other trigonometric functions of  $\theta$  in terms of  $\cos \theta$ .

107. Use the definitions of sine and cosine to derive the Pythagorean identity  $\sin^2 \theta + \cos^2 \theta = 1$ .

108. **Writing** Use the Pythagorean identity  $\sin^2 \theta + \cos^2 \theta = 1$  to derive the other Pythagorean identities  $1 + \tan^2 \theta = \sec^2 \theta$  and  $1 + \cot^2 \theta = \csc^2 \theta$ . Discuss how to remember these identities and other fundamental identities.

### Review

In Exercises 109–112, sketch the graph of the function. (Include two full periods.)

109.  $f(x) = \frac{1}{2} \sin \pi x$

110.  $f(x) = -2 \tan \frac{\pi x}{2}$

111.  $f(x) = \frac{1}{2} \cot\left(x + \frac{\pi}{4}\right)$

112.  $f(x) = \frac{3}{2} \cos(x - \pi) + 3$



## 5.2 Verifying Trigonometric Identities

### Introduction

In this section, you will study techniques for verifying trigonometric identities. In the next section, you will study techniques for solving trigonometric equations. The key to both verifying identities *and* solving equations is your ability to use the fundamental identities and the rules of algebra to rewrite trigonometric expressions.

Remember that a *conditional equation* is an equation that is true for only some of the values in its domain. For example, the conditional equation

$$\sin x = 0 \quad \text{Conditional equation}$$

is true only for  $x = n\pi$ , where  $n$  is an integer. When you find these values, you are *solving* the equation.

On the other hand, an equation that is true for all real values in the domain of the variable is an *identity*. For example, the familiar equation

$$\sin^2 x = 1 - \cos^2 x \quad \text{Identity}$$

is true for all real numbers  $x$ . So, it is an identity.

### Verifying Trigonometric Identities

Verifying that a trigonometric equation is an identity is quite different from solving an equation. There is no well-defined set of rules to follow in verifying trigonometric identities, and the process is best learned by practice.

#### Guidelines for Verifying Trigonometric Identities

1. Work with one side of the equation at a time. It is often better to work with the more complicated side first.
2. Look for opportunities to factor an expression, add fractions, square a binomial, or create a monomial denominator.
3. Look for opportunities to use the fundamental identities. Note which functions are in the final expression you want. Sines and cosines pair up well, as do secants and tangents, and cosecants and cotangents.
4. If the preceding guidelines do not help, try converting all terms to sines and cosines.
5. Always try *something*. Even making an attempt that leads to a dead end provides insight.

Verifying trigonometric identities is a useful process if you need to convert a trigonometric expression into a form that is more useful algebraically. When you verify an identity, you cannot assume that the two sides of the equation are equal because you are trying to verify that they are equal. As a result, when verifying identities, you cannot use operations such as adding the same quantity to each side of the equation or cross multiplication.

#### What you should learn

- Verify trigonometric identities.

#### Why you should learn it

You can use trigonometric identities to rewrite trigonometric expressions. For instance, Exercise 67 on page 355 shows you how trigonometric identities can be used to solve a problem about the coefficient of friction for an object on an inclined plane.

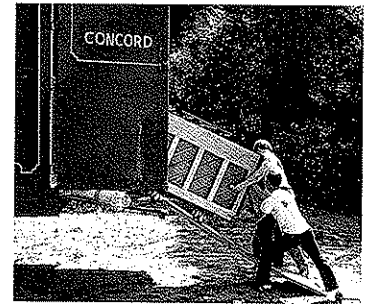

Nancy Dudley/Stock Boston

**Example 1** Verifying a Trigonometric Identity

Verify the identity  $\frac{\sec^2 \theta - 1}{\sec^2 \theta} = \sin^2 \theta$ .

**Solution**

Because the left side is more complicated, start with it.

$$\begin{aligned} \frac{\sec^2 \theta - 1}{\sec^2 \theta} &= \frac{(\tan^2 \theta + 1) - 1}{\sec^2 \theta} && \text{Pythagorean identity} \\ &= \frac{\tan^2 \theta}{\sec^2 \theta} && \text{Simplify.} \\ &= \tan^2 \theta (\cos^2 \theta) && \text{Reciprocal identity} \\ &= \frac{\sin^2 \theta}{\cos^2 \theta} (\cos^2 \theta) && \text{Quotient identity} \\ &= \sin^2 \theta && \text{Simplify.} \end{aligned}$$

 **Checkpoint** Now try Exercise 5.

There can be more than one way to verify an identity. Here is another way to verify the identity in Example 1.

$$\begin{aligned} \frac{\sec^2 \theta - 1}{\sec^2 \theta} &= \frac{\sec^2 \theta}{\sec^2 \theta} - \frac{1}{\sec^2 \theta} && \text{Rewrite as the difference of fractions.} \\ &= 1 - \cos^2 \theta && \text{Reciprocal identity} \\ &= \sin^2 \theta && \text{Pythagorean identity} \end{aligned}$$

**STUDY TIP**

Remember that an identity is only true for all real values in the domain of the variable. For instance, in Example 1 the identity is not true when  $\theta = \pi/2$  because  $\sec^2 \theta$  is not defined when  $\theta = \pi/2$ .

**Example 2** Combining Fractions Before Using Identities

Verify the identity  $\frac{1}{1 - \sin \alpha} + \frac{1}{1 + \sin \alpha} = 2 \sec^2 \alpha$ .

**Algebraic Solution**

$$\begin{aligned} \frac{1}{1 - \sin \alpha} + \frac{1}{1 + \sin \alpha} &= \frac{1 + \sin \alpha + 1 - \sin \alpha}{(1 - \sin \alpha)(1 + \sin \alpha)} && \text{Add fractions.} \\ &= \frac{2}{1 - \sin^2 \alpha} && \text{Simplify.} \\ &= \frac{2}{\cos^2 \alpha} && \text{Pythagorean identity} \\ &= 2 \sec^2 \alpha && \text{Reciprocal identity} \end{aligned}$$

 **Checkpoint** Now try Exercise 31.

**Numerical Solution**

Use the *table* feature of a graphing utility set in *radian* mode to create a table that shows the values of  $y_1 = 1/(1 - \sin x) + 1/(1 + \sin x)$  and  $y_2 = 2/\cos^2 x$  for different values of  $x$ , as shown in Figure 5.5. From the table, you can see that the values appear to be identical, so  $1/(1 - \sin x) + 1/(1 + \sin x) = 2 \sec^2 x$  appears to be an identity.

X	Y1	Y2
-0.5	2.5969	2.5969
-0.25	2.1304	2.1304
0	2.0000	2.0000
0.25	2.1304	2.1304
0.5	2.5969	2.5969
1	6.851	6.851

X = 1.5

Figure 5.5

**Example 3** Verifying a Trigonometric IdentityVerify the identity  $(\tan^2 x + 1)(\cos^2 x - 1) = -\tan^2 x$ .**Algebraic Solution**

By applying identities before multiplying, you obtain the following.

$$\begin{aligned}
 (\tan^2 x + 1)(\cos^2 x - 1) &= (\sec^2 x)(-\sin^2 x) && \text{Pythagorean identities} \\
 &= -\frac{\sin^2 x}{\cos^2 x} && \text{Reciprocal identity} \\
 &= -\left(\frac{\sin x}{\cos x}\right)^2 && \text{Rule of exponents} \\
 &= -\tan^2 x && \text{Quotient identity}
 \end{aligned}$$

 **Checkpoint** Now try Exercise 39.

**Graphical Solution**

Use a graphing utility set in *radian* mode to graph the left side of the identity  $y_1 = (\tan^2 x + 1)(\cos^2 x - 1)$  and the right side of the identity  $y_2 = -\tan^2 x$  in the same viewing window, as shown in Figure 5.6. (Select the *line* style for  $y_1$  and the *path* style for  $y_2$ .) Because the graphs appear to coincide,  $(\tan^2 x + 1)(\cos^2 x - 1) = -\tan^2 x$  appears to be an identity.

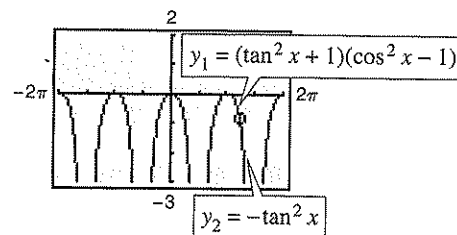

Figure 5.6

**Example 4** Converting to Sines and CosinesVerify the identity  $\tan x + \cot x = \sec x \csc x$ .**Solution**

In this case there appear to be no fractions to add, no products to find, and no opportunities to use the Pythagorean identities. So, try converting the left side into sines and cosines.

$$\begin{aligned}
 \tan x + \cot x &= \frac{\sin x}{\cos x} + \frac{\cos x}{\sin x} && \text{Quotient identities} \\
 &= \frac{\sin^2 x + \cos^2 x}{\cos x \sin x} && \text{Add fractions.} \\
 &= \frac{1}{\cos x \sin x} && \text{Pythagorean identity} \\
 &= \frac{1}{\cos x} \cdot \frac{1}{\sin x} && \text{Product of fractions} \\
 &= \sec x \csc x && \text{Reciprocal identities}
 \end{aligned}$$

 **Checkpoint** Now try Exercise 41.

**TECHNOLOGY TIP**

Although a graphing utility can be useful in helping to verify an identity, you must use algebraic techniques to produce a valid proof. For example, graph the two functions

$$y_1 = \sin 50x$$

$$y_2 = \sin 2x$$

in a trigonometric viewing window. Although their graphs seem identical,  $\sin 50x \neq \sin 2x$ .

Recall from algebra that *rationalizing the denominator* using conjugates is, on occasion, a powerful simplification technique. A related form of this technique works for simplifying trigonometric expressions as well. For instance, to simplify  $1/(1 - \cos x)$ , multiply the numerator and the denominator by  $1 + \cos x$ .

$$\begin{aligned}\frac{1}{1 - \cos x} &= \frac{1}{1 - \cos x} \left( \frac{1 + \cos x}{1 + \cos x} \right) \\ &= \frac{1 + \cos x}{1 - \cos^2 x} \\ &= \frac{1 + \cos x}{\sin^2 x} \\ &= \csc^2 x(1 + \cos x)\end{aligned}$$

As shown above,  $\csc^2 x(1 + \cos x)$  is considered a simplified form of  $1/(1 - \cos x)$  because the expression does not contain any fractions.

### Example 5 Verifying a Trigonometric Identity

Verify the identity

$$\sec x + \tan x = \frac{\cos x}{1 - \sin x}$$

#### Algebraic Solution

Work with the *right* side because you can create a monomial denominator by multiplying the numerator and denominator by  $(1 + \sin x)$ .

$$\begin{aligned}\frac{\cos x}{1 - \sin x} &= \frac{\cos x}{1 - \sin x} \left( \frac{1 + \sin x}{1 + \sin x} \right) && \text{Multiply numerator and} \\ &&& \text{denominator by} \\ &&& (1 + \sin x). \\ &= \frac{\cos x + \cos x \sin x}{1 - \sin^2 x} && \text{Multiply.} \\ &= \frac{\cos x + \cos x \sin x}{\cos^2 x} && \text{Pythagorean identity} \\ &= \frac{\cos x}{\cos^2 x} + \frac{\cos x \sin x}{\cos^2 x} && \text{Separate fractions.} \\ &= \frac{1}{\cos x} + \frac{\sin x}{\cos x} && \text{Simplify.} \\ &= \sec x + \tan x && \text{Identities}\end{aligned}$$

 **Checkpoint** Now try Exercise 47.

#### TECHNOLOGY SUPPORT

For instructions on how to use the *radian* and *dot* modes, see Appendix A; for specific keystrokes, go to the text website at [college.hmco.com](http://college.hmco.com).

#### Graphical Solution

Use a graphing utility set in *radian* and *dot* modes to graph  $y_1 = \sec x + \tan x = 1/\cos x + \tan x$  and  $y_2 = \cos x/(1 - \sin x)$  in the same viewing window, as shown in Figure 5.7. Because the graphs appear to coincide,  $\sec x + \tan x = \cos x/(1 - \sin x)$  appears to be an identity.

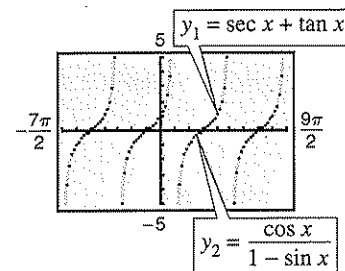

Figure 5.7

In Examples 1 through 5, you have been verifying trigonometric identities by working with one side of the equation and converting it to the form given on the other side. On occasion it is practical to work with each side *separately* to obtain one common form equivalent to both sides. This is illustrated in Example 6.

**Example 6** Working with Each Side Separately

Verify the identity  $\frac{\cot^2 \theta}{1 + \csc \theta} = \frac{1 - \sin \theta}{\sin \theta}$ .

**Solution**

Working with the left side, you have

$$\begin{aligned} \frac{\cot^2 \theta}{1 + \csc \theta} &= \frac{\csc^2 \theta - 1}{1 + \csc \theta} && \text{Pythagorean identity} \\ &= \frac{(\csc \theta - 1)(\csc \theta + 1)}{1 + \csc \theta} && \text{Factor.} \\ &= \csc \theta - 1. && \text{Simplify.} \end{aligned}$$

Now, simplifying the right side, you have

$$\begin{aligned} \frac{1 - \sin \theta}{\sin \theta} &= \frac{1}{\sin \theta} - \frac{\sin \theta}{\sin \theta} && \text{Separate fractions.} \\ &= \csc \theta - 1. && \text{Reciprocal identity} \end{aligned}$$

The identity is verified because both sides are equal to  $\csc \theta - 1$ .

 **Checkpoint** Now try Exercise 49.

In Example 7, powers of trigonometric functions are rewritten as more complicated sums of products of trigonometric functions. This is a common procedure used in calculus.

**Example 7** Examples from Calculus

Verify each identity.

a.  $\tan^4 x = \tan^2 x \sec^2 x - \tan^2 x$       b.  $\sin^3 x \cos^4 x = (\cos^4 x - \cos^6 x) \sin x$

**Solution**

a.  $\tan^4 x = (\tan^2 x)(\tan^2 x)$       Write as separate factors.  
 $= \tan^2 x(\sec^2 x - 1)$       Pythagorean identity  
 $= \tan^2 x \sec^2 x - \tan^2 x$       Multiply.

b.  $\sin^3 x \cos^4 x = \sin^2 x \cos^4 x \sin x$       Write as separate factors.  
 $= (1 - \cos^2 x) \cos^4 x \sin x$       Pythagorean identity  
 $= (\cos^4 x - \cos^6 x) \sin x$       Multiply.

 **Checkpoint** Now try Exercise 63.

**TECHNOLOGY TIP** Remember that you can use a graphing utility to assist in verifying an identity by creating a table or by graphing.

## 5.2 Exercises

## Vocabulary Check

In Exercises 1 and 2, fill in the blanks.

1. An equation that is true for only some values in its domain is called a \_\_\_\_\_ equation.
2. An equation that is true for all real values in its domain is called an \_\_\_\_\_.

In Exercises 3–10, fill in the blank to complete the trigonometric identity.

3.  $\frac{1}{\tan u} = \underline{\hspace{2cm}}$
4.  $\frac{1}{\csc u} = \underline{\hspace{2cm}}$
5.  $\frac{\sin u}{\cos u} = \underline{\hspace{2cm}}$
6.  $\frac{1}{\sec u} = \underline{\hspace{2cm}}$
7.  $\sin^2 u + \underline{\hspace{2cm}} = 1$
8.  $\sin\left(\frac{\pi}{2} - u\right) = \underline{\hspace{2cm}}$
9.  $\tan(-u) = \underline{\hspace{2cm}}$
10.  $\sec(-u) = \underline{\hspace{2cm}}$

In Exercises 1–10, verify the identity.

1.  $\sin t \csc t = 1$
2.  $\sec y \cos y = 1$
3.  $\frac{\csc^2 x}{\cot x} = \csc x \sec x$
4.  $\frac{\sin^2 t}{\tan^2 t} = \cos^2 t$
5.  $\cos^2 \beta - \sin^2 \beta = 1 - 2 \sin^2 \beta$
6.  $\cos^2 \beta - \sin^2 \beta = 2 \cos^2 \beta - 1$
7.  $\tan^2 \theta + 5 = \sec^2 \theta + 4$
8.  $2 - \csc^2 z = 1 - \cot^2 z$
9.  $(1 + \sin x)(1 - \sin x) = \cos^2 x$
10.  $\cot^2 y(\sec^2 y - 1) = 1$

**Numerical, Graphical, and Algebraic Analysis** In Exercises 11–18, use a graphing utility to complete the table and graph the functions in the same viewing window. Use both the table and the graph as evidence that  $y_1 = y_2$ . Then verify the identity algebraically.

$x$	0.2	0.4	0.6	0.8	1.0	1.2	1.4
$y_1$							
$y_2$							

11.  $y_1 = \frac{1}{\sec x \tan x}$ ,  $y_2 = \csc x - \sin x$
12.  $y_1 = \frac{\csc x - 1}{1 - \sin x}$ ,  $y_2 = \csc x$

13.  $y_1 = \csc x - \sin x$ ,  $y_2 = \cos x \cot x$
14.  $y_1 = \sec x - \cos x$ ,  $y_2 = \sin x \tan x$
15.  $y_1 = \sin x + \cos x \cot x$ ,  $y_2 = \csc x$
16.  $y_1 = \cos x + \sin x \tan x$ ,  $y_2 = \sec x$
17.  $y_1 = \frac{1}{\tan x} + \frac{1}{\cot x}$ ,  $y_2 = \tan x + \cot x$
18.  $y_1 = \frac{1}{\sin x} - \frac{1}{\csc x}$ ,  $y_2 = \csc x - \sin x$

**Error Analysis** In Exercises 19 and 20, describe the error.

19. ~~$$\begin{aligned} (1 + \tan x)[1 + \cot(-x)] &= (1 + \tan x)(1 + \cot x) \\ &= 1 + \cot x + \tan x + \tan x \cot x \\ &= 1 + \cot x + \tan x + 1 \\ &= 2 + \cot x + \tan x \end{aligned}$$~~
20. ~~$$\begin{aligned} \frac{1 + \sec(-\theta)}{\sin(-\theta) + \tan(-\theta)} &= \frac{1 - \sec \theta}{\sin \theta - \tan \theta} \\ &= \frac{1 - \sec \theta}{(\sin \theta) \left[ 1 - \left( \frac{1}{\cos \theta} \right) \right]} \\ &= \frac{1 - \sec \theta}{\sin \theta (1 - \sec \theta)} \\ &= \frac{1}{\sin \theta} = \csc \theta \end{aligned}$$~~

In Exercises 21–30, verify the identity.

21.  $\sin^{1/2} x \cos x - \sin^{5/2} x \cos x = \cos^3 x \sqrt{\sin x}$
22.  $\sec^6 x (\sec x \tan x) - \sec^4 x (\sec x \tan x) = \sec^5 x \tan^3 x$
23.  $\tan\left(\frac{\pi}{2} - x\right) \sec x = \csc x$
24.  $\frac{\cos[(\pi/2) - x]}{\sin[(\pi/2) - x]} = \tan x$
25.  $\frac{\csc(-x)}{\sec(-x)} = -\cot x$
26.  $(1 + \sin y)[1 + \sin(-y)] = \cos^2 y$
27.  $\frac{\cos(-\theta)}{1 + \sin(-\theta)} = \sec \theta + \tan \theta$
28.  $\frac{1 + \csc(-\theta)}{\cos(-\theta) + \cot(-\theta)} = \sec \theta$
29.  $\frac{\sin x \cos y + \cos x \sin y}{\cos x \cos y - \sin x \sin y} = \frac{\tan x + \tan y}{1 - \tan x \tan y}$
30.  $\frac{\tan x + \tan y}{1 - \tan x \tan y} = \frac{\cot x + \cot y}{\cot x \cot y - 1}$

In Exercises 31–38, verify the identity algebraically. Use the *table* feature of a graphing utility to check your result numerically.

31.  $\frac{\cos x - \cos y}{\sin x + \sin y} + \frac{\sin x - \sin y}{\cos x + \cos y} = 0$
32.  $\frac{\tan x + \cot y}{\tan x \cot y} = \tan y + \cot x$
33.  $\sqrt{\frac{1 + \sin \theta}{1 - \sin \theta}} = \frac{1 + \sin \theta}{|\cos \theta|}$
34.  $\sqrt{\frac{1 - \cos \theta}{1 + \cos \theta}} = \frac{1 - \cos \theta}{|\sin \theta|}$
35.  $\cos^2 x + \cos^2\left(\frac{\pi}{2} - x\right) = 1$
36.  $\sec^2 y - \cot^2\left(\frac{\pi}{2} - y\right) = 1$
37.  $\sin x \csc\left(\frac{\pi}{2} - x\right) = \tan x$
38.  $\csc^2\left(\frac{\pi}{2} - x\right) - 1 = \tan^2 x$

In Exercises 39–50, verify the identity algebraically. Use a graphing utility to check your result graphically.

39.  $2 \sec^2 x - 2 \sec^2 x \sin^2 x - \sin^2 x - \cos^2 x = 1$

40.  $\csc x (\csc x - \sin x) + \frac{\sin x - \cos x}{\sin x} + \cot x = \csc^2 x$
41.  $\frac{\tan x \cot x}{\cos x} = \sec x$
42.  $\frac{1 + \csc \theta}{\sec \theta} - \cot \theta = \cos \theta$
43.  $\csc^4 x - 2 \csc^2 x + 1 = \cot^4 x$
44.  $\sin x (1 - 2 \cos^2 x + \cos^4 x) = \sin^5 x$
45.  $\sec^4 \theta - \tan^4 \theta = 1 + 2 \tan^2 \theta$
46.  $\csc^4 \theta - \cot^4 \theta = 2 \csc^2 \theta - 1$
47.  $\frac{\sin \beta}{1 - \cos \beta} = \frac{1 + \cos \beta}{\sin \beta}$
48.  $\frac{\cot \alpha}{\csc \alpha - 1} = \frac{\csc \alpha + 1}{\cot \alpha}$
49.  $\frac{\tan^3 \alpha - 1}{\tan \alpha - 1} = \tan^2 \alpha + \tan \alpha + 1$
50.  $\frac{\sin^3 \beta + \cos^3 \beta}{\sin \beta + \cos \beta} = 1 - \sin \beta \cos \beta$

**Conjecture** In Exercises 51–54, use a graphing utility to graph the trigonometric function. Use the graph to make a conjecture about a simplification of the expression. Verify the resulting identity algebraically.

51.  $y = \frac{1}{\cot x + 1} + \frac{1}{\tan x + 1}$
52.  $y = \frac{\cos x}{1 - \tan x} + \frac{\sin x \cos x}{\sin x - \cos x}$
53.  $y = \frac{1}{\sin x} - \frac{\cos^2 x}{\sin x}$
54.  $y = \sin t + \frac{\cot^2 t}{\csc t}$

In Exercises 55–58, use the properties of logarithms and trigonometric identities to verify the identity.

55.  $\ln|\cot \theta| = \ln|\cos \theta| - \ln|\sin \theta|$
56.  $\ln|\sec \theta| = -\ln|\cos \theta|$
57.  $-\ln(1 + \cos \theta) = \ln(1 - \cos \theta) - 2 \ln|\sin \theta|$
58.  $-\ln|\csc \theta + \cot \theta| = \ln|\csc \theta - \cot \theta|$

In Exercises 59–62, use the cofunction identities to evaluate the expression without using a calculator.

59.  $\sin^2 25^\circ + \sin^2 65^\circ$       60.  $\cos^2 14^\circ + \cos^2 76^\circ$

61.  $\cos^2 20^\circ + \cos^2 52^\circ + \cos^2 38^\circ + \cos^2 70^\circ$

62.  $\sin^2 12^\circ + \sin^2 40^\circ + \sin^2 50^\circ + \sin^2 78^\circ$

**In Exercises 63–66, powers of trigonometric functions are rewritten to be useful in calculus. Verify the identity.**

63.  $\tan^5 x = \tan^3 x \sec^2 x - \tan^3 x$

64.  $\sec^4 x \tan^2 x = (\tan^2 x + \tan^4 x) \sec^2 x$

65.  $\cos^3 x \sin^2 x = (\sin^2 x - \sin^4 x) \cos x$

66.  $\sin^4 x + \cos^4 x = 1 - 2 \cos^2 x + 2 \cos^4 x$

**67. Friction** The forces acting on an object weighing  $W$  units on an inclined plane positioned at an angle of  $\theta$  with the horizontal (see figure) are modeled by

$$\mu W \cos \theta = W \sin \theta$$

where  $\mu$  is the coefficient of friction. Solve the equation for  $\mu$  and simplify the result.

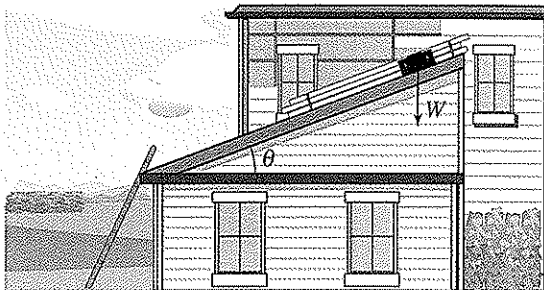

**68. Shadow Length** The length  $s$  of the shadow cast by a vertical gnomon (a device used to tell time) of height  $h$  when the angle of the sun above the horizon is  $\theta$  can be modeled by the equation

$$s = \frac{h \sin(90^\circ - \theta)}{\sin \theta}$$

Show that the equation is equivalent to  $s = h \cot \theta$ .

### Synthesis

**True or False?** In Exercises 69–72, determine whether the statement is true or false. Justify your answer.

69. There can be more than one way to verify a trigonometric identity.

70. Of the six trigonometric functions, two are even.

71. The equation  $\sin^2 \theta + \cos^2 \theta = 1 + \tan^2 \theta$  is an identity, because  $\sin^2(0) + \cos^2(0) = 1$  and  $1 + \tan^2(0) = 1$ .

72.  $\sin(x^2) = \sin^2(x)$

**Think About It** In Exercises 73 and 74, explain why the equation is not an identity and find one value of the variable for which the equation is not true.

73.  $\sqrt{\tan^2 x} = \tan x$

74.  $\sin \theta = \sqrt{1 - \cos^2 \theta}$

75. Verify that for all integers  $n$ ,

$$\cos \left[ \frac{(2n+1)\pi}{2} \right] = 0.$$

76. Verify that for all integers  $n$ ,

$$\sin \left[ \frac{(12n+1)\pi}{6} \right] = \frac{1}{2}.$$

### Review

In Exercises 77–80, find a polynomial function with real coefficients that has the given zeros. (There are many correct answers.)

77.  $1, 8i, -8i$

78.  $i, -i, 4i, -4i$

79.  $4, 6+i, 6-i$

80.  $0, 0, 2, 1-i$

In Exercises 81–84, sketch the graph of the function by hand.

81.  $f(x) = 2^x + 3$

82.  $f(x) = -2^{x-3}$

83.  $f(x) = 2^{-x} + 1$

84.  $f(x) = 2^{x-1} + 3$

In Exercises 85–88, state the quadrant in which  $\theta$  lies.

85.  $\csc \theta > 0$  and  $\tan \theta < 0$

86.  $\cot \theta > 0$  and  $\cos \theta < 0$

87.  $\sec \theta > 0$  and  $\sin \theta < 0$

88.  $\cot \theta > 0$  and  $\sec \theta < 0$

In Exercises 89–92, solve the right triangle shown in the figure. Round your answer to two decimal places.

89.  $B = 80^\circ, a = 16$

90.  $A = 28^\circ, c = 20$

91.  $a = 14, b = 8$

92.  $b = 6.2, c = 12.54$

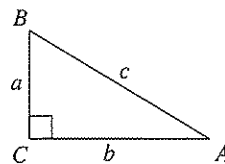



## 5.3 Solving Trigonometric Equations

### Introduction

To solve a trigonometric equation, use standard algebraic techniques such as collecting like terms and factoring. Your preliminary goal is to isolate the trigonometric function involved in the equation.

### Example 1 Solving a Trigonometric Equation

$$\begin{array}{ll} 2 \sin x - 1 = 0 & \text{Original equation} \\ 2 \sin x = 1 & \text{Add 1 to each side.} \\ \sin x = \frac{1}{2} & \text{Divide each side by 2.} \end{array}$$

To solve for  $x$ , note in Figure 5.8 that the equation  $\sin x = \frac{1}{2}$  has solutions  $x = \pi/6$  and  $x = 5\pi/6$  in the interval  $[0, 2\pi)$ . Moreover, because  $\sin x$  has a period of  $2\pi$ , there are infinitely many other solutions, which can be written as

$$x = \frac{\pi}{6} + 2n\pi \quad \text{and} \quad x = \frac{5\pi}{6} + 2n\pi \quad \text{General solution}$$

where  $n$  is an integer, as shown in Figure 5.8.

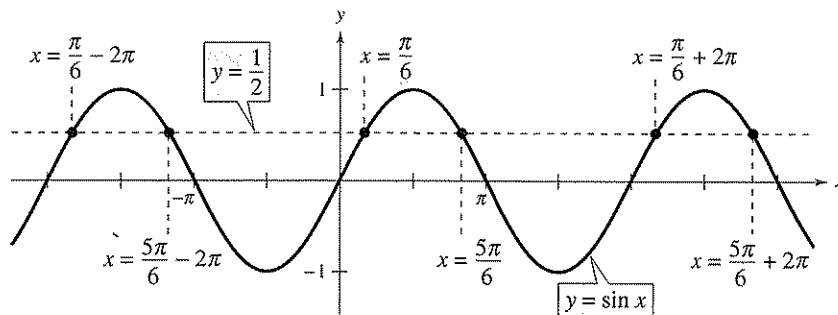

Figure 5.8

 **Checkpoint** Now try Exercise 7.

Figure 5.9 verifies that the equation  $\sin x = \frac{1}{2}$  has infinitely many solutions. Any angles that are coterminal with  $\pi/6$  or  $5\pi/6$  are also solutions of the equation.

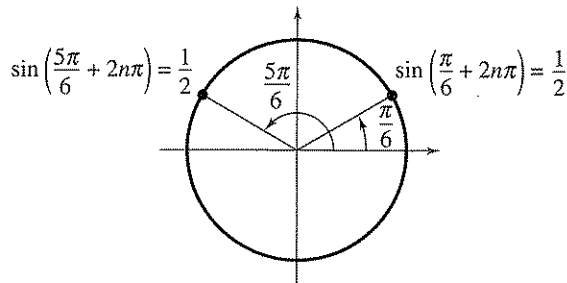

Figure 5.9

### What you should learn

- Use standard algebraic techniques to solve trigonometric equations.
- Solve trigonometric equations of quadratic type.
- Solve trigonometric equations involving multiple angles.
- Use inverse trigonometric functions to solve trigonometric equations.

### Why you should learn it

You can use trigonometric equations to solve a variety of real-life problems. For instance, Exercise 72 on page 366 shows you how solving a trigonometric equation can help answer questions about the position of the sun in Cheyenne, Wyoming.

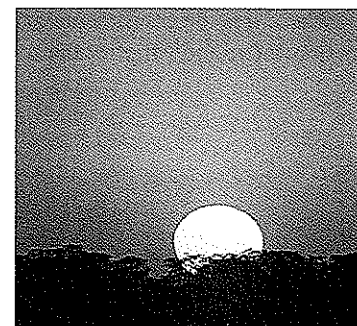

SuperStock

**Example 2** Collecting Like Terms

Find all solutions of  $\sin x + \sqrt{2} = -\sin x$  in the interval  $[0, 2\pi)$ .

**Algebraic Solution**

Rewrite the equation so that  $\sin x$  is isolated on one side of the equation.

$$\begin{aligned} \sin x + \sqrt{2} &= -\sin x && \text{Write original equation.} \\ \sin x + \sin x &= -\sqrt{2} && \text{Add } \sin x \text{ to and subtract } \\ &&& \sqrt{2} \text{ from each side.} \\ 2 \sin x &= -\sqrt{2} && \text{Combine like terms.} \\ \sin x &= -\frac{\sqrt{2}}{2} && \text{Divide each side by 2.} \end{aligned}$$

The solutions in the interval  $[0, 2\pi)$  are

$$x = \frac{5\pi}{4} \quad \text{and} \quad x = \frac{7\pi}{4}$$

 **Checkpoint** Now try Exercise 17.

**Numerical Solution**

Use the *table* feature of a graphing utility set in *radian* mode to create a table that shows the values of  $y_1 = \sin x + \sqrt{2}$  and  $y_2 = -\sin x$  for different values of  $x$ . Your table should go from  $x = 0$  to  $x = 2\pi$  using increments of  $\pi/8$ , as shown in Figure 5.10. From the table, you can see that the values of  $y_1$  and  $y_2$  appear to be identical when  $x \approx 3.927 \approx 5\pi/4$  and  $x \approx 5.4978 \approx 7\pi/4$ . These values are the approximate solutions of  $\sin x + \sqrt{2} = -\sin x$ .

X	Y1	Y2
0	1.4142	0
0.3927	1.4142	0.38268
0.7854	1.4142	0.70711
1.1781	1.4142	0.92388
1.5708	1.4142	1
1.9635	1.4142	0.92388
2.3562	1.4142	0.70711
2.7489	1.4142	0.38268
3.1416	1.4142	0
3.5343	1.4142	-0.38268
3.9270	1.4142	-0.70711
4.3197	1.4142	-0.92388
4.7124	1.4142	-1
5.1051	1.4142	-0.92388
5.4978	1.4142	-0.70711
5.8905	1.4142	-0.38268
6.2832	1.4142	0

X=5.497787143782

Figure 5.10

**Example 3** Extracting Square Roots

Solve  $3 \tan^2 x - 1 = 0$ .

**Solution**

Rewrite the equation so that  $\tan x$  is isolated on one side of the equation.

$$\begin{aligned} 3 \tan^2 x &= 1 && \text{Add 1 to each side.} \\ \tan^2 x &= \frac{1}{3} && \text{Divide each side by 3.} \\ \tan x &= \pm \frac{1}{\sqrt{3}} && \text{Extract square roots.} \end{aligned}$$

Because  $\tan x$  has a period of  $\pi$ , first find all solutions in the interval  $[0, \pi)$ . These are  $x = \pi/6$  and  $x = 5\pi/6$ . Finally, add multiples of  $\pi$  to each of these solutions to get the general form

$$x = \frac{\pi}{6} + n\pi \quad \text{and} \quad x = \frac{5\pi}{6} + n\pi \quad \text{General solution}$$

where  $n$  is an integer. The graph of  $y = 3 \tan^2 x - 1$ , shown in Figure 5.11, confirms this result.

 **Checkpoint** Now try Exercise 19.

Recall that the solutions of an equation correspond to the  $x$ -intercepts of the graph of the equation. For instance, the graph in Figure 5.11 has  $x$ -intercepts at  $\pi/6, 5\pi/6, 7\pi/6$ , and so on.

**TECHNOLOGY SUPPORT**

For instructions on how to use the *table* feature, see Appendix A; for specific keystrokes, go to the text website at [college.hmco.com](http://college.hmco.com).

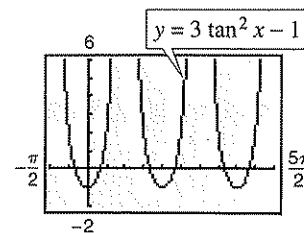

Figure 5.11

The equations in Examples 1, 2, and 3 involved only one trigonometric function. When two or more functions occur in the same equation, collect all terms on one side and try to separate the functions by factoring or by using appropriate identities. This may produce factors that yield no solutions, as illustrated in Example 4.

### Example 4 Factoring

Solve  $\cot x \cos^2 x = 2 \cot x$ .

#### Solution

Begin by rewriting the equation so that all terms are collected on one side of the equation.

$$\cot x \cos^2 x = 2 \cot x \quad \text{Write original equation.}$$

$$\cot x \cos^2 x - 2 \cot x = 0 \quad \text{Subtract } 2 \cot x \text{ from each side.}$$

$$\cot x (\cos^2 x - 2) = 0 \quad \text{Factor.}$$

By setting each of these factors equal to zero, you obtain the following.

$$\begin{aligned} \cot x = 0 \quad \text{and} \quad \cos^2 x - 2 = 0 \\ \cos^2 x = 2 \\ \cos x = \pm \sqrt{2} \end{aligned}$$

The equation  $\cot x = 0$  has the solution  $x = \pi/2$  [in the interval  $(0, \pi)$ ]. No solution is obtained for  $\cos x = \pm \sqrt{2}$  because  $\pm \sqrt{2}$  are outside the range of the cosine function. Because  $\cot x$  has a period of  $\pi$ , the general form of the solution is obtained by adding multiples of  $\pi$  to  $x = \pi/2$ , to get

$$x = \frac{\pi}{2} + n\pi \quad \text{General solution}$$

where  $n$  is an integer. The graph of  $y = \cot x \cos^2 x - 2 \cot x$  (in *dot* mode), shown in Figure 5.12, confirms this result.

 **Checkpoint** Now try Exercise 21.

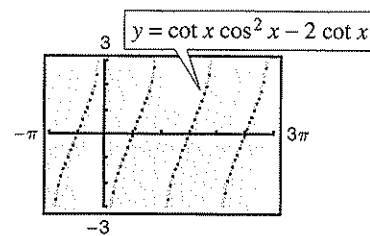

Figure 5.12

### Exploration

Using the equation from Example 4, explain what would happen if you divided each side of the equation by  $\cot x$ . Is this a correct method to use when solving equations?

## Equations of Quadratic Type

Many trigonometric equations are of quadratic type. Here are a few examples.

*Quadratic in sin x*

$$2 \sin^2 x - \sin x - 1 = 0$$

$$2(\sin x)^2 - \sin x - 1 = 0$$

*Quadratic in sec x*

$$\sec^2 x - 3 \sec x - 2 = 0$$

$$(\sec x)^2 - 3 \sec x - 2 = 0$$

To solve equations of this type, factor the quadratic or, if factoring is not possible, use the Quadratic Formula.

**Example 5** Factoring an Equation of Quadratic Type

Find all solutions of  $2 \sin^2 x - \sin x - 1 = 0$  in the interval  $[0, 2\pi)$ .

**Algebraic Solution**

Treating the equation as quadratic in  $\sin x$  and factoring produces the following.

$$2 \sin^2 x - \sin x - 1 = 0 \quad \text{Write original equation.}$$

$$(2 \sin x + 1)(\sin x - 1) = 0 \quad \text{Factor.}$$

Setting each factor equal to zero, you obtain the following solutions in the interval  $[0, 2\pi)$ .

$$2 \sin x + 1 = 0 \quad \text{and} \quad \sin x - 1 = 0$$

$$\sin x = -\frac{1}{2} \quad \sin x = 1$$

$$x = \frac{7\pi}{6}, \frac{11\pi}{6} \quad x = \frac{\pi}{2}$$

 **Checkpoint** Now try Exercise 31.

**Graphical Solution**

Use a graphing utility set in *radian* mode to graph  $y = 2 \sin^2 x - \sin x - 1$  for  $0 \leq x < 2\pi$ , as shown in Figure 5.13. Use the *zero* or *root* feature or the *zoom* and *trace* features to approximate the  $x$ -intercepts to be

$$x \approx 1.571 \approx \frac{\pi}{2}, \quad x \approx 3.665 \approx \frac{7\pi}{6}, \quad x \approx 5.760 \approx \frac{11\pi}{6}.$$

These values are the approximate solutions of  $2 \sin^2 x - \sin x - 1 = 0$ .

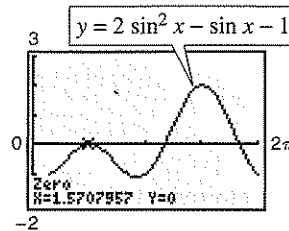

Figure 5.13

When working with an equation of quadratic type, be sure that the equation involves a *single* trigonometric function, as shown in the next example.

**Example 6** Rewriting with a Single Trigonometric Function

Solve  $2 \sin^2 x + 3 \cos x - 3 = 0$ .

**Solution**

Begin by rewriting the equation so that it has only cosine functions.

$$2 \sin^2 x + 3 \cos x - 3 = 0 \quad \text{Write original equation.}$$

$$2(1 - \cos^2 x) + 3 \cos x - 3 = 0 \quad \text{Pythagorean identity}$$

$$2 \cos^2 x - 3 \cos x + 1 = 0 \quad \text{Combine like terms and multiply each side by } -1.$$

$$(2 \cos x - 1)(\cos x - 1) = 0 \quad \text{Factor.}$$

By setting each factor equal to zero, you can find the solutions in the interval  $[0, 2\pi)$  to be  $x = 0$ ,  $x = \pi/3$ , and  $x = 5\pi/3$ . Because  $\cos x$  has a period of  $2\pi$ , the general solution is

$$x = 2n\pi, \quad x = \frac{\pi}{3} + 2n\pi, \quad x = \frac{5\pi}{3} + 2n\pi \quad \text{General solution}$$

where  $n$  is an integer. The graph of  $y = 2 \sin^2 x + 3 \cos x - 3$ , shown in Figure 5.14, confirms this result.

 **Checkpoint** Now try Exercise 33.

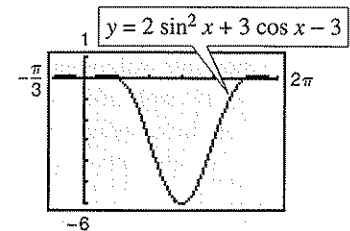

Figure 5.14

Sometimes you must square each side of an equation to obtain a quadratic. Because this procedure can introduce extraneous solutions, you should check any solutions in the original equation to see whether they are valid or extraneous.

### Example 7 Squaring and Converting to Quadratic Type

Find all solutions of  $\cos x + 1 = \sin x$  in the interval  $[0, 2\pi)$ .

#### Solution

It is not clear how to rewrite this equation in terms of a single trigonometric function. See what happens when you square each side of the equation.

$\cos x + 1 = \sin x$	Write original equation.
$\cos^2 x + 2 \cos x + 1 = \sin^2 x$	Square each side.
$\cos^2 x + 2 \cos x + 1 = 1 - \cos^2 x$	Pythagorean identity
$2 \cos^2 x + 2 \cos x = 0$	Combine like terms.
$2 \cos x(\cos x + 1) = 0$	Factor.

Setting each factor equal to zero produces the following.

$2 \cos x = 0$	and	$\cos x + 1 = 0$
$\cos x = 0$		$\cos x = -1$
$x = \frac{\pi}{2}, \frac{3\pi}{2}$		$x = \pi$

Because you squared the original equation, check for extraneous solutions.

#### Check

$\cos \frac{\pi}{2} + 1 \stackrel{?}{=} \sin \frac{\pi}{2}$	Substitute $\pi/2$ for $x$ .
$0 + 1 = 1$	Solution checks. ✓
$\cos \frac{3\pi}{2} + 1 \stackrel{?}{=} \sin \frac{3\pi}{2}$	Substitute $3\pi/2$ for $x$ .
$0 + 1 \neq -1$	Solution does not check.
$\cos \pi + 1 \stackrel{?}{=} \sin \pi$	Substitute $\pi$ for $x$ .
$-1 + 1 = 0$	Solution checks. ✓

Of the three possible solutions,  $x = 3\pi/2$  is extraneous. So, in the interval  $[0, 2\pi)$ , the only solutions are  $x = \pi/2$  and  $x = \pi$ . The graph of  $y = \cos x + 1 - \sin x$ , shown in Figure 5.15, confirms this result because the graph has two  $x$ -intercepts (at  $x = \pi/2$  and  $x = \pi$ ) in the interval  $[0, 2\pi)$ .

✓ **Checkpoint** Now try Exercise 35.

### Exploration

Use a graphing utility to confirm the solutions found in Example 7 in two different ways. Do both methods produce the same  $x$ -values? Which method do you prefer? Why?

- Graph both sides of the equation and find the  $x$ -coordinates of the points at which the graphs intersect.

*Left side:*  $y = \cos x + 1$

*Right side:*  $y = \sin x$

- Graph the equation  $y = \cos x + 1 - \sin x$  and find the  $x$ -intercepts of the graph.

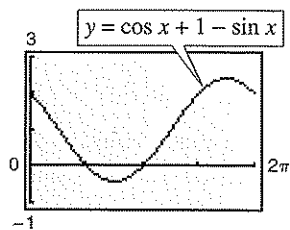

Figure 5.15

## Functions Involving Multiple Angles

### Example 8 Functions of Multiple Angles

Solve  $2 \cos 3t - 1 = 0$ .

**Solution**

$$2 \cos 3t - 1 = 0$$

Write original equation.

$$2 \cos 3t = 1$$

Add 1 to each side.

$$\cos 3t = \frac{1}{2}$$

Divide each side by 2.

In the interval  $[0, 2\pi)$ , you know that  $3t = \pi/3$  and  $3t = 5\pi/3$  are the only solutions. So in general, you have  $3t = \pi/3 + 2n\pi$  and  $3t = 5\pi/3 + 2n\pi$ . Dividing this result by 3, you obtain the general solution

$$t = \frac{\pi}{9} + \frac{2n\pi}{3} \quad \text{and} \quad t = \frac{5\pi}{9} + \frac{2n\pi}{3} \quad \text{General solution}$$

where  $n$  is an integer. This solution is confirmed graphically in Figure 5.16.

 **Checkpoint** Now try Exercise 39.

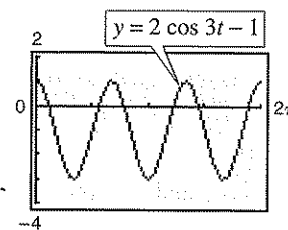

Figure 5.16

### Example 9 Functions of Multiple Angles

Solve  $3 \tan \frac{x}{2} + 3 = 0$ .

**Solution**

$$3 \tan \frac{x}{2} + 3 = 0$$

Write original equation.

$$3 \tan \frac{x}{2} = -3$$

Subtract 3 from each side.

$$\tan \frac{x}{2} = -1$$

Divide each side by 3.

In the interval  $[0, \pi)$ , you know that  $x/2 = 3\pi/4$  is the only solution. So in general, you have  $x/2 = 3\pi/4 + n\pi$ . Multiplying this result by 2, you obtain the general solution

$$x = \frac{3\pi}{2} + 2n\pi \quad \text{General solution}$$

where  $n$  is an integer. This solution is confirmed graphically in Figure 5.17.

 **Checkpoint** Now try Exercise 45.

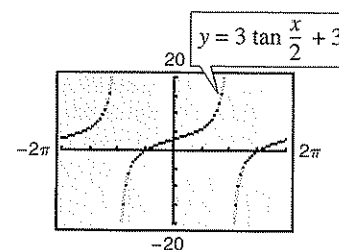

Figure 5.17

## Using Inverse Functions

## Example 10 Using Inverse Functions

Find all solutions of  $\sec^2 x - 2 \tan x = 4$ .

**Solution**

$$\sec^2 x - 2 \tan x = 4$$

Write original equation.

$$1 + \tan^2 x - 2 \tan x - 4 = 0$$

Pythagorean identity

$$\tan^2 x - 2 \tan x - 3 = 0$$

Combine like terms.

$$(\tan x - 3)(\tan x + 1) = 0$$

Factor.

Setting each factor equal to zero, you obtain two solutions in the interval  $(-\pi/2, \pi/2)$ . [Recall that the range of the inverse tangent function is  $(-\pi/2, \pi/2)$ .]

$$\tan x = 3 \quad \text{and} \quad \tan x = -1$$

$$x = \arctan 3 \quad x = \arctan(-1) = -\frac{\pi}{4}$$

Finally, because  $\tan x$  has a period of  $\pi$ , add multiples of  $\pi$  to obtain

$$x = \arctan 3 + n\pi \quad \text{and} \quad x = -\frac{\pi}{4} + n\pi \quad \text{General solution}$$

where  $n$  is an integer. This solution is confirmed graphically in Figure 5.18.

 **Checkpoint** Now try Exercise 29.

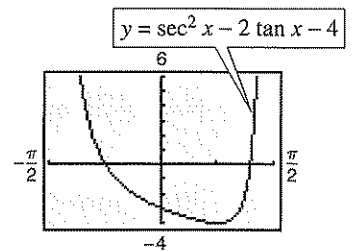

Figure 5.18

With some trigonometric equations, there is no reasonable way to find the solutions algebraically. In such cases, you can still use a graphing utility to approximate the solutions.

## Example 11 Approximating Solutions

Approximate the solutions of  $x = 2 \sin x$  in the interval  $[-\pi, \pi]$ .

**Solution**

Use a graphing utility to graph  $y = x - 2 \sin x$  in the interval  $[-\pi, \pi]$ . Using the *zero* or *root* feature or the *zoom* and *trace* features, you can see that the solutions are  $x \approx -1.8955$ ,  $x = 0$ , and  $x \approx 1.8955$ . (See Figure 5.19.)

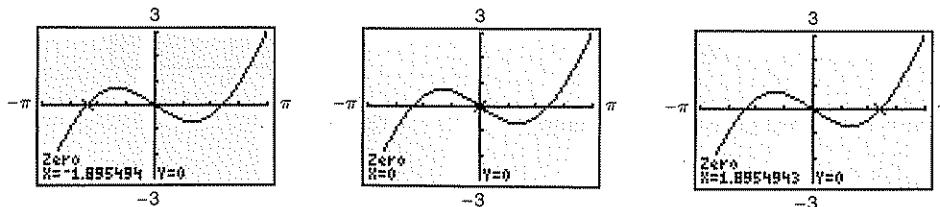

Figure 5.19  $y = x - 2 \sin x$

 **Checkpoint** Now try Exercise 59.

### Example 12 Surface Area of a Honeycomb



The surface area of a honeycomb is given by the equation

$$S = 6hs + \frac{3}{2}s^2 \left( \frac{\sqrt{3} - \cos \theta}{\sin \theta} \right), \quad 0 < \theta \leq 90^\circ$$

where  $h = 2.4$  inches,  $s = 0.75$  inch, and  $\theta$  is the angle indicated in Figure 5.20.

- What value of  $\theta$  gives a surface area of 12 square inches?
- What value of  $\theta$  gives the minimum surface area?

#### Solution

- Let  $h = 2.4$ ,  $s = 0.75$ , and  $S = 12$ .

$$S = 6hs + \frac{3}{2}s^2 \left( \frac{\sqrt{3} - \cos \theta}{\sin \theta} \right)$$

$$12 = 6(2.4)(0.75) + \frac{3}{2}(0.75)^2 \left( \frac{\sqrt{3} - \cos \theta}{\sin \theta} \right)$$

$$12 = 10.8 + 0.84375 \left( \frac{\sqrt{3} - \cos \theta}{\sin \theta} \right)$$

$$0 = 0.84375 \left( \frac{\sqrt{3} - \cos \theta}{\sin \theta} \right) - 1.2$$

Using a graphing utility set to *degree* mode, you can graph the function

$$y = 0.84375 \left( \frac{\sqrt{3} - \cos x}{\sin x} \right) - 1.2.$$

Using the *zero* or *root* feature or the *zoom* and *trace* features, you can determine that  $\theta \approx 49.9^\circ$  and  $\theta \approx 59.9^\circ$ . (See Figure 5.21.)

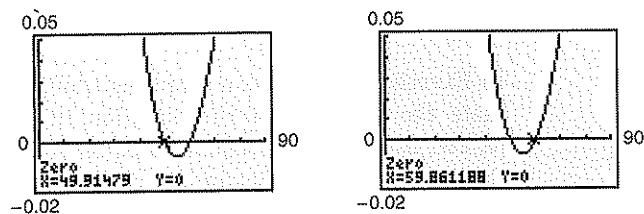

Figure 5.21  $y = 0.84375 \left( \frac{\sqrt{3} - \cos x}{\sin x} \right) - 1.2$

- From part (a), let  $h = 2.4$  and  $s = 0.75$  to obtain

$$S = 10.8 + 0.84375 \left( \frac{\sqrt{3} - \cos \theta}{\sin \theta} \right).$$

Graph this function using a graphing utility set to *degree* mode. Use the *minimum* feature or the *zoom* and *trace* features to approximate the minimum point on the graph, which occurs at  $\theta \approx 54.7^\circ$ , as shown in Figure 5.22.

**Checkpoint** Now try Exercise 63.

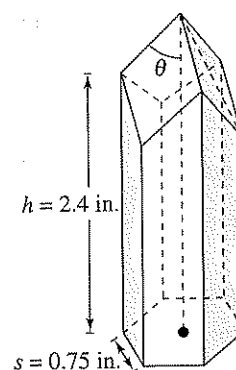

Figure 5.20

#### TECHNOLOGY SUPPORT

For instructions on how to use the *degree* mode and the *minimum* feature, see Appendix A; for specific keystrokes, go to the text website at [college.hmco.com](http://college.hmco.com).

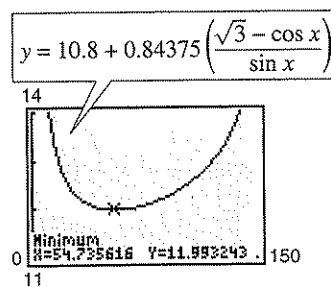

Figure 5.22

#### STUDY TIP

By using calculus, it can be shown that the exact minimum value is

$$\theta = \arccos\left(\frac{1}{\sqrt{3}}\right) \approx 54.7356^\circ.$$



## 5.3 Exercises

## Vocabulary Check

Fill in the blanks.

- The equation  $2 \cos x - 1 = 0$  has the solutions  $x = \frac{\pi}{3} + 2n\pi$  and  $x = \frac{5\pi}{3} + 2n\pi$ , which are called \_\_\_\_\_ solutions.
- The equation  $\tan^2 x - 5 \tan x + 6 = 0$  is an equation of \_\_\_\_\_ type.
- A solution to an equation that does not satisfy the original equation is called an \_\_\_\_\_ solution.

In Exercises 1–6, verify that each  $x$ -value is a solution of the equation.

- $2 \cos x - 1 = 0$   
(a)  $x = \frac{\pi}{3}$  (b)  $x = \frac{5\pi}{3}$
- $\sec x - 2 = 0$   
(a)  $x = \frac{\pi}{3}$  (b)  $x = \frac{5\pi}{3}$
- $3 \tan^2 2x - 1 = 0$   
(a)  $x = \frac{\pi}{12}$  (b)  $x = \frac{5\pi}{12}$
- $4 \cos^2 2x - 2 = 0$   
(a)  $x = \frac{\pi}{8}$  (b)  $x = \frac{7\pi}{8}$
- $2 \sin^2 x - \sin x - 1 = 0$   
(a)  $x = \frac{\pi}{2}$  (b)  $x = \frac{7\pi}{6}$
- $\sec^4 x - 3 \sec^2 x - 4 = 0$   
(a)  $x = \frac{2\pi}{3}$  (b)  $x = \frac{5\pi}{3}$

In Exercises 7–16, solve the equation.

- $2 \cos x + 1 = 0$
- $\sqrt{3} \sec x - 2 = 0$
- $\cot x + 1 = 0$
- $3 \csc^2 x - 4 = 0$
- $3 \cot^2 x - 1 = 0$
- $4 \cos^2 x - 1 = 0$
- $\cos x(\cos x - 1) = 0$
- $\sin^2 x = 3 \cos^2 x$
- $(3 \tan^2 x - 1)(\tan^2 x - 3) = 0$
- $\sqrt{2} \sin x + 1 = 0$

In Exercises 17–30, find all solutions of the equation in the interval  $[0, 2\pi)$  algebraically. Use the *table* feature of a graphing utility to check your answers numerically.

- $\tan x + \sqrt{3} = 0$
- $\csc^2 x - 2 = 0$
- $3 \tan^3 x = \tan x$
- $2 \sin^2 x = 2 + \cos x$
- $\sec^2 x - \sec x = 2$
- $\sec x \csc x = 2 \csc x$
- $2 \sin x + \csc x = 0$
- $\sec x + \tan x = 1$
- $\cos x + \sin x \tan x = 2$
- $\sin^2 x + \cos x + 1 = 0$
- $\sec^2 x + \tan x = 3$
- $2 \cos 2x + \cos x - 1 = 0$
- $2 \sin x + 1 = 0$
- $\tan^2 x - 1 = 0$

In Exercises 31–38, use a graphing utility to approximate the solutions of the equation in the interval  $[0, 2\pi)$  by setting the equation equal to 0, graphing the new equation, and using the *zero* or *root* feature to approximate the  $x$ -intercepts of the graph.

- $2 \sin^2 x + 3 \sin x + 1 = 0$
- $2 \sec^2 x + \tan^2 x - 3 = 0$
- $4 \sin^2 x = 2 \cos x + 1$
- $\csc^2 x = 3 \csc x + 4$
- $\csc x + \cot x = 1$
- $4 \sin x = \cos x - 2$
- $\frac{\cos x \cot x}{1 - \sin x} = 3$
- $\frac{1 + \sin x}{\cos x} + \frac{\cos x}{1 + \sin x} = 4$

In Exercises 39–46, solve the multiple angle equation.

$$39. \sin 2x = -\frac{\sqrt{3}}{2} \qquad 40. \sec 4x = 2$$

$$41. 2 \sin^2 2x = 1 \qquad 42. \tan^2 3x = 3$$

$$43. \tan 3x(\tan x - 1) = 0$$

$$44. \cos 2x(2 \cos x + 1) = 0$$

$$45. \cos \frac{x}{2} = \frac{\sqrt{2}}{2} \qquad 46. \tan \frac{x}{3} = 1$$

In Exercises 47–50, approximate the  $x$ -intercepts of the graph. Use a graphing utility to check your solutions.

$$47. y = \sin \frac{\pi x}{2} + 1 \qquad 48. y = \sin \pi x + \cos \pi x$$

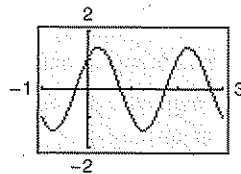
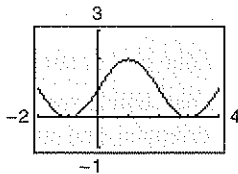

$$49. y = \tan^2\left(\frac{\pi x}{6}\right) - 3 \qquad 50. y = \sec^4\left(\frac{\pi x}{8}\right) - 4$$

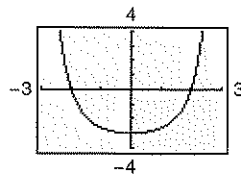
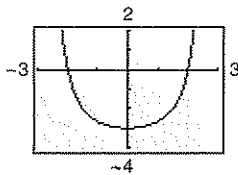

In Exercises 51–58, use a graphing utility to approximate the solutions of the equation in the interval  $[0, 2\pi)$ .

$$51. 2 \cos x - \sin x = 0 \qquad 52. 2 \sin x + \cos x = 0$$

$$53. x \tan x - 1 = 0 \qquad 54. 2x \sin x - 2 = 0$$

$$55. \sec^2 x + 0.5 \tan x = 1$$

$$56. \csc^2 x + 0.5 \cot x = 5$$

$$57. 12 \sin^2 x - 13 \sin x + 3 = 0$$

$$58. 3 \tan^2 x + 4 \tan x - 4 = 0$$

In Exercises 59–62, use a graphing utility to approximate the solutions (to three decimal places) of the equation in the given interval.

$$59. 3 \tan^2 x + 5 \tan x - 4 = 0, \quad \left[-\frac{\pi}{2}, \frac{\pi}{2}\right]$$

$$60. \cos^2 x - 2 \cos x - 1 = 0, \quad [0, \pi]$$

$$61. 4 \cos^2 x - 2 \sin x + 1 = 0, \quad \left[-\frac{\pi}{2}, \frac{\pi}{2}\right]$$

$$62. 2 \sec^2 x + \tan x - 6 = 0, \quad \left[-\frac{\pi}{2}, \frac{\pi}{2}\right]$$

In Exercises 63 and 64, (a) use a graphing utility to graph the function and approximate the maximum and minimum points of the graph in the interval  $[0, 2\pi]$ , and (b) solve the trigonometric equation and verify that the  $x$ -coordinates of the maximum and minimum points of  $f$  are among its solutions (the trigonometric equation is found using calculus).

Function                      Trigonometric Equation

$$63. f(x) = \sin x + \cos x \qquad \cos x - \sin x = 0$$

$$64. f(x) = 2 \sin x + \cos 2x \qquad 2 \cos x - 4 \sin x \cos x = 0$$

**Fixed Point** In Exercises 65 and 66, find the smallest positive fixed point of the function  $f$ . [A fixed point of a function  $f$  is a real number  $c$  such that  $f(c) = c$ .]

$$65. f(x) = \tan \frac{\pi x}{4} \qquad 66. f(x) = \cos x$$

67. **Graphical Reasoning** Consider the function

$$f(x) = \cos \frac{1}{x}$$

and its graph shown in the figure.

(a) What is the domain of the function?

(b) Identify any symmetry or asymptotes of the graph.

(c) Describe the behavior of the function as  $x \rightarrow 0$ .

(d) How many solutions does the equation

$$\cos \frac{1}{x} = 0$$

have in the interval  $[-1, 1]$ ? Find the solutions.

(e) Does the equation  $\cos(1/x) = 0$  have a greatest solution? If so, approximate the solution. If not, explain.

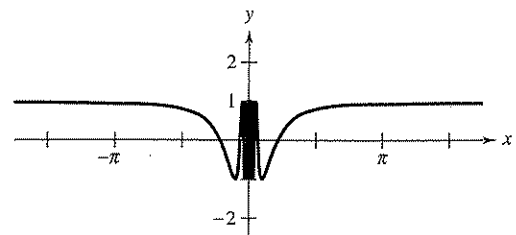

68. **Graphical Reasoning** Consider the function

$$f(x) = \frac{\sin x}{x}$$

and its graph shown in the figure.

- What is the domain of the function?
- Identify any symmetry or asymptotes of the graph.
- Describe the behavior of the function as  $x \rightarrow 0$ .
- How many solutions does the equation

$$\frac{\sin x}{x} = 0$$

have in the interval  $[-8, 8]$ ? Find the solutions.

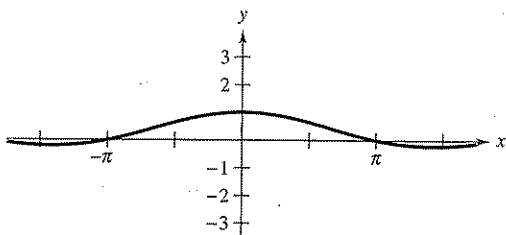

69. **Harmonic Motion** A weight is oscillating on the end of a spring (see figure). The position of the weight relative to the point of equilibrium is given by

$$y = \frac{1}{12}(\cos 8t - 3 \sin 8t)$$

where  $y$  is the displacement (in meters) and  $t$  is the time (in seconds). Find the times when the weight is at the point of equilibrium ( $y = 0$ ) for  $0 \leq t \leq 1$ .

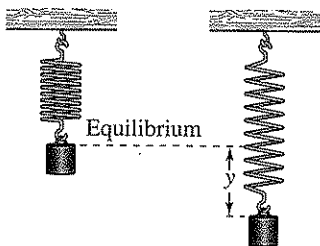

70. **Damped Harmonic Motion** The displacement from equilibrium of a weight oscillating on the end of a spring is given by  $y = 1.56e^{-0.22t} \cos 4.9t$ , where  $y$  is the displacement (in feet) and  $t$  is the time (in seconds). Use a graphing utility to graph the displacement function for  $0 \leq t \leq 10$ . Find the time beyond which the displacement does not exceed 1 foot from equilibrium.

71. **Sales** The monthly sales  $S$  (in thousands of units) of lawn mowers are approximated by

$$S = 74.50 - 43.75 \cos \frac{\pi t}{6}$$

where  $t$  is the time (in months), with  $t = 1$  corresponding to January. Determine the months during which sales exceed 100,000 units.

72. **Position of the Sun** Cheyenne, Wyoming has a latitude of  $41^\circ$  N. At this latitude, the position of the sun at sunrise can be modeled by

$$D = 31 \sin\left(\frac{2\pi}{365}t - 1.4\right)$$

where  $t$  is the time (in days) and  $t = 1$  represents January 1. In this model,  $D$  represents the number of degrees north or south of due east that the sun rises. Use a graphing utility to determine the days that the sun is more than  $20^\circ$  north of due east at sunrise.

73. **Projectile Motion** A batted baseball leaves the bat at an angle of  $\theta$  with the horizontal and an initial velocity of  $v_0 = 100$  feet per second. The ball is caught by an outfielder 300 feet from home plate (see figure). Find  $\theta$  if the range  $r$  of a projectile is given by

$$r = \frac{1}{32}v_0^2 \sin 2\theta.$$

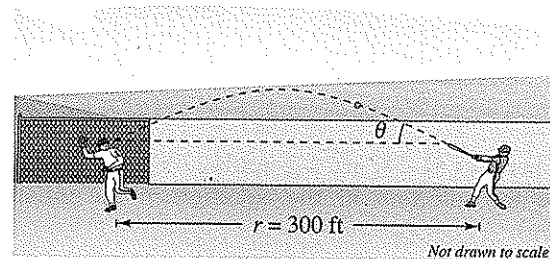

74. **Area** The area of a rectangle inscribed in one arch of the graph of  $y = \cos x$  (see figure) is given by

$$A = 2x \cos x, \quad 0 \leq x \leq \frac{\pi}{2}.$$

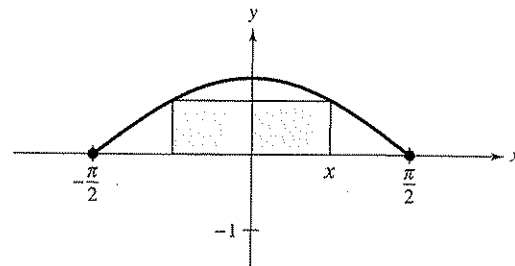

- (a) Use a graphing utility to graph the area function, and approximate the area of the largest inscribed rectangle.
- (b) Determine the values of  $x$  for which  $A \geq 1$ .

**75. Data Analysis** The table shows the unemployment rate  $r$  for the years 1990 through 2001 in the United States. The time  $t$  is measured in years, with  $t = 0$  corresponding to 1990. (Source: U.S. Bureau of Labor Statistics)

Time, $t$	Rate, $r$
0	5.6
1	6.8
2	7.5
3	6.9
4	6.1
5	5.6
6	5.4
7	4.9
8	4.5
9	4.2
10	4.0
11	4.8

- (a) Use a graphing utility to create a scatter plot of the data.
- (b) A model for the data is given by  $r = 1.39 \sin(0.48t + 0.42) + 5.51$ . Graph the model with the scatter plot in part (a). Is the model a good fit for the original data? Explain.
- (c) What term in the model gives the average unemployment rate? What is the rate?
- (d) Economists study the lengths of business cycles, such as cycles in the unemployment rate. Based on this short span of time, use the model to give the length of this cycle.
- (e) Use the model to estimate the next time the unemployment rate will be 6.5% or less.

**76. Quadratic Approximation** Consider the function

$$f(x) = 3 \sin(0.6x - 2).$$

- (a) Approximate the zero of the function in the interval  $[0, 6]$ .

- (b) A quadratic approximation agreeing with  $f$  at  $x = 5$  is

$$g(x) = -0.45x^2 + 5.52x - 13.70.$$

Use a graphing utility to graph  $f$  and  $g$  in the same viewing window. Describe the result.

- (c) Use the Quadratic Formula to find the zeros of  $g$ . Compare the zero in the interval  $[0, 6]$  with the result of part (a).

### Synthesis

**True or False?** In Exercises 77–79, determine whether the statement is true or false. Justify your answer.

77. All trigonometric equations have either an infinite number of solutions or no solution.
78. The solutions of any trigonometric equation can always be found from its solutions in the interval  $[0, 2\pi)$ .
79. If you correctly solve a trigonometric equation down to the statement  $\sin x = 3.4$ , then you can finish solving the equation by using an inverse trigonometric function.

80. **Writing** Describe the difference between verifying an identity and solving an equation.

### Review

In Exercises 81–84, convert the angle measure from degrees to radians. Round your answer to three decimal places.

81.  $124^\circ$

82.  $486^\circ$

83.  $-0.41^\circ$

84.  $-210.55^\circ$

In Exercises 85 and 86, solve for  $x$ .

85.

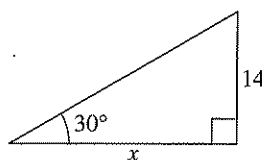

86.

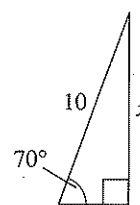

87. **Distance** From the 100-foot roof of a condominium on the coast, a tourist sights a cruise ship. The angle of depression is  $2.5^\circ$ . How far is the ship from the shoreline?

## 5.4 Sum and Difference Formulas

### Using Sum and Difference Formulas

In this section and the following section, you will study the uses of several trigonometric identities and formulas. See Appendix C for proofs of these formulas.

#### Sum and Difference Formulas

$$\sin(u + v) = \sin u \cos v + \cos u \sin v \quad \tan(u + v) = \frac{\tan u + \tan v}{1 - \tan u \tan v}$$

$$\sin(u - v) = \sin u \cos v - \cos u \sin v$$

$$\cos(u + v) = \cos u \cos v - \sin u \sin v \quad \tan(u - v) = \frac{\tan u - \tan v}{1 + \tan u \tan v}$$

$$\cos(u - v) = \cos u \cos v + \sin u \sin v$$

#### Exploration

Use a graphing utility to graph  $y_1 = \cos(x + 2)$  and  $y_2 = \cos x + \cos 2$  in the same viewing window. What can you conclude about the graphs? Is it true that  $\cos(x + 2) = \cos x + \cos 2$ ?

Use a graphing utility to graph  $y_1 = \sin(x + 4)$  and  $y_2 = \sin x + \sin 4$  in the same viewing window. What can you conclude about the graphs? Is it true that  $\sin(x + 4) = \sin x + \sin 4$ ?

Examples 1 and 2 show how **sum and difference formulas** can be used to find exact values of trigonometric functions involving sums or differences of special angles.

#### Example 1 Evaluating a Trigonometric Function

Find the exact value of  $\cos 75^\circ$ .

##### Solution

To find the exact value of  $\cos 75^\circ$ , use the fact that  $75^\circ = 30^\circ + 45^\circ$ . Consequently, the formula for  $\cos(u + v)$  yields

$$\begin{aligned} \cos 75^\circ &= \cos(30^\circ + 45^\circ) \\ &= \cos 30^\circ \cos 45^\circ - \sin 30^\circ \sin 45^\circ \\ &= \frac{\sqrt{3}}{2} \left( \frac{\sqrt{2}}{2} \right) - \frac{1}{2} \left( \frac{\sqrt{2}}{2} \right) \\ &= \frac{\sqrt{6} - \sqrt{2}}{4} \end{aligned}$$

Try checking this result on your calculator. You will find that  $\cos 75^\circ \approx 0.259$ .

 **Checkpoint** Now try Exercise 1.

#### What you should learn

- Use sum and difference formulas to evaluate trigonometric functions, verify identities, and solve trigonometric equations.

#### Why you should learn it

You can use sum and difference formulas to rewrite trigonometric expressions. For instance, Exercise 63 on page 373 shows how to use sum and difference formulas to rewrite a trigonometric expression in a form that helps you find the equation of a standing wave.

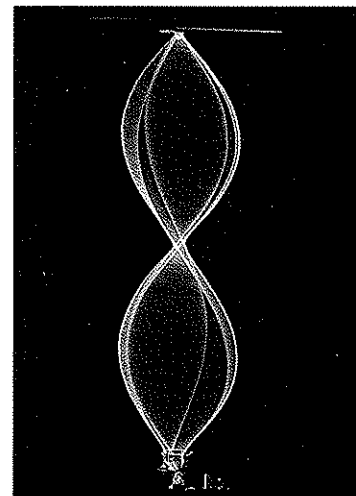

Richard Megna/Fundamental Photographs

**Example 2** Evaluating a Trigonometric Function

Find the exact value of  $\sin \frac{\pi}{12}$ .

**Solution**

Using the fact that  $\frac{\pi}{12} = \frac{\pi}{3} - \frac{\pi}{4}$  together with the formula for  $\sin(u - v)$ , you obtain

$$\begin{aligned}\sin \frac{\pi}{12} &= \sin\left(\frac{\pi}{3} - \frac{\pi}{4}\right) = \sin \frac{\pi}{3} \cos \frac{\pi}{4} - \cos \frac{\pi}{3} \sin \frac{\pi}{4} \\ &= \frac{\sqrt{3}}{2} \left(\frac{\sqrt{2}}{2}\right) - \frac{1}{2} \left(\frac{\sqrt{2}}{2}\right) = \frac{\sqrt{6} - \sqrt{2}}{4}.\end{aligned}$$

✓ **Checkpoint** Now try Exercise 3.

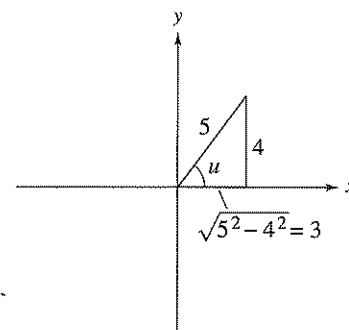

Figure 5.23

**Example 3** Evaluating a Trigonometric Expression

Find the exact value of  $\sin(u + v)$  given

$$\sin u = \frac{4}{5}, \text{ where } 0 < u < \frac{\pi}{2}, \text{ and } \cos v = -\frac{12}{13}, \text{ where } \frac{\pi}{2} < v < \pi.$$

**Solution**

Because  $\sin u = 4/5$  and  $u$  is in Quadrant I,  $\cos u = 3/5$ , as shown in Figure 5.23. Because  $\cos v = -12/13$  and  $v$  is in Quadrant II,  $\sin v = 5/13$ , as shown in Figure 5.24. You can find  $\sin(u + v)$  as follows.

$$\begin{aligned}\sin(u + v) &= \sin u \cos v + \cos u \sin v \\ &= \left(\frac{4}{5}\right) \left(-\frac{12}{13}\right) + \left(\frac{3}{5}\right) \left(\frac{5}{13}\right) = -\frac{48}{65} + \frac{15}{65} = -\frac{33}{65}\end{aligned}$$

✓ **Checkpoint** Now try Exercise 35.

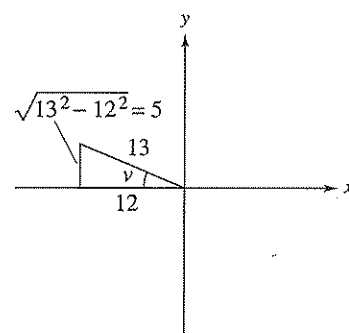

Figure 5.24

**Example 4** An Application of a Sum Formula

Write  $\cos(\arctan 1 + \arccos x)$  as an algebraic expression.

**Solution**

This expression fits the formula for  $\cos(u + v)$ . Angles  $u = \arctan 1$  and  $v = \arccos x$  are shown in Figure 5.25.

$$\begin{aligned}\cos(u + v) &= \cos(\arctan 1) \cos(\arccos x) - \sin(\arctan 1) \sin(\arccos x) \\ &= \frac{1}{\sqrt{2}} \cdot x - \frac{1}{\sqrt{2}} \cdot \sqrt{1 - x^2} = \frac{x - \sqrt{1 - x^2}}{\sqrt{2}}.\end{aligned}$$

✓ **Checkpoint** Now try Exercise 43.

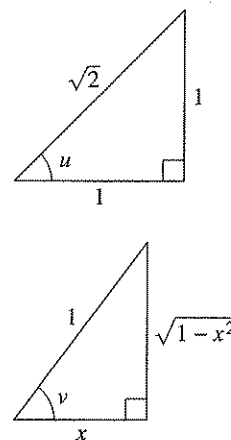

Figure 5.25

**Example 5** Proving a Cofunction Identity

Prove the cofunction identity  $\cos\left(\frac{\pi}{2} - x\right) = \sin x$ .

**Solution**

Using the formula for  $\cos(u - v)$ , you have

$$\begin{aligned}\cos\left(\frac{\pi}{2} - x\right) &= \cos\frac{\pi}{2}\cos x + \sin\frac{\pi}{2}\sin x \\ &= (0)(\cos x) + (1)(\sin x) \\ &= \sin x.\end{aligned}$$

 **Checkpoint** Now try Exercise 47.

Sum and difference formulas can be used to derive **reduction formulas** involving expressions such as

$$\sin\left(\theta + \frac{n\pi}{2}\right) \quad \text{and} \quad \cos\left(\theta + \frac{n\pi}{2}\right), \text{ where } n \text{ is an integer.}$$

**Example 6** Deriving Reduction Formulas

Simplify each expression.

a.  $\cos\left(\theta - \frac{3\pi}{2}\right)$       b.  $\tan(\theta + 3\pi)$

**Solution**

a. Using the formula for  $\cos(u - v)$ , you have

$$\begin{aligned}\cos\left(\theta - \frac{3\pi}{2}\right) &= \cos\theta\cos\frac{3\pi}{2} + \sin\theta\sin\frac{3\pi}{2} \\ &= (\cos\theta)(0) + (\sin\theta)(-1) \\ &= -\sin\theta.\end{aligned}$$

b. Using the formula for  $\tan(u + v)$ , you have

$$\begin{aligned}\tan(\theta + 3\pi) &= \frac{\tan\theta + \tan 3\pi}{1 - \tan\theta\tan 3\pi} \\ &= \frac{\tan\theta + 0}{1 - (\tan\theta)(0)} \\ &= \tan\theta.\end{aligned}$$

Note that the period of  $\tan\theta$  is  $\pi$ , so the period of  $\tan(\theta + 3\pi)$  is the same as the period of  $\tan\theta$ .

 **Checkpoint** Now try Exercise 51.

**Example 7** Solving a Trigonometric Equation

Find all solutions of  $\sin\left(x + \frac{\pi}{4}\right) + \sin\left(x - \frac{\pi}{4}\right) = -1$  in the interval  $[0, 2\pi)$ .

**Algebraic Solution**

Using sum and difference formulas, rewrite the equation as

$$\sin x \cos \frac{\pi}{4} + \cos x \sin \frac{\pi}{4} + \sin x \cos \frac{\pi}{4} - \cos x \sin \frac{\pi}{4} = -1$$

$$2 \sin x \cos \frac{\pi}{4} = -1$$

$$2(\sin x)\left(\frac{\sqrt{2}}{2}\right) = -1$$

$$\sin x = -\frac{1}{\sqrt{2}}$$

$$\sin x = -\frac{\sqrt{2}}{2}$$

So, the only solutions in the interval  $[0, 2\pi)$  are

$$x = \frac{5\pi}{4} \quad \text{and} \quad x = \frac{7\pi}{4}$$

 **Checkpoint** Now try Exercise 55.

**Graphical Solution**

Use a graphing utility set in *radian* mode to graph  $y = \sin\left(x + \frac{\pi}{4}\right) + \sin\left(x - \frac{\pi}{4}\right) + 1$ , as shown in Figure 5.26. Use the *zero* or *root* feature or the *zoom* and *trace* features to approximate the  $x$ -intercepts in the interval  $[0, 2\pi)$  to be

$$x \approx 3.927 \approx \frac{5\pi}{4} \quad \text{and} \quad x \approx 5.498 \approx \frac{7\pi}{4}$$

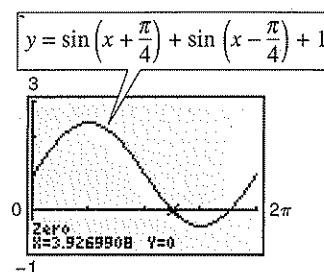

Figure 5.26

The next example was taken from calculus. It is used to derive the formula for the derivative of the sine function.

**Example 8** An Application from Calculus

Verify  $\frac{\sin(x+h) - \sin x}{h} = (\cos x)\left(\frac{\sin h}{h}\right) - (\sin x)\left(\frac{1 - \cos h}{h}\right)$ ,  $h \neq 0$ .

**Solution**

Using the formula for  $\sin(u+v)$ , you have

$$\begin{aligned} \frac{\sin(x+h) - \sin x}{h} &= \frac{\sin x \cos h + \cos x \sin h - \sin x}{h} \\ &= \frac{\cos x \sin h - \sin x(1 - \cos h)}{h} \\ &= (\cos x)\left(\frac{\sin h}{h}\right) - (\sin x)\left(\frac{1 - \cos h}{h}\right). \end{aligned}$$

 **Checkpoint** Now try Exercise 77.

**TECHNOLOGY SUPPORT**

For instructions on how to use the *zero* or *root* feature and the *zoom* and *trace* features, see Appendix A; for specific keystrokes, go to the text website at [college.hmco.com](http://college.hmco.com).



## 5.4 Exercises

## Vocabulary Check

Fill in the blank to complete the trigonometric formula.

1.  $\sin(u - v) = \underline{\hspace{2cm}}$

2.  $\cos(u + v) = \underline{\hspace{2cm}}$

3.  $\tan(u + v) = \underline{\hspace{2cm}}$

4.  $\sin(u + v) = \underline{\hspace{2cm}}$

5.  $\cos(u - v) = \underline{\hspace{2cm}}$

6.  $\tan(u - v) = \underline{\hspace{2cm}}$

In Exercises 1–6, find the exact value of each expression.

1. (a)  $\cos(240^\circ - 0^\circ)$  (b)  $\cos 240^\circ - \cos 0^\circ$

2. (a)  $\sin(390^\circ + 120^\circ)$  (b)  $\sin 390^\circ + \sin 120^\circ$

3. (a)  $\cos\left(\frac{\pi}{6} + \frac{\pi}{3}\right)$  (b)  $\cos \frac{\pi}{6} + \cos \frac{\pi}{3}$

4. (a)  $\sin\left(\frac{2\pi}{3} + \frac{3\pi}{4}\right)$  (b)  $\sin \frac{2\pi}{3} + \sin \frac{3\pi}{4}$

5. (a)  $\sin(315^\circ - 60^\circ)$  (b)  $\sin 315^\circ - \sin 60^\circ$

6. (a)  $\sin\left(\frac{7\pi}{6} - \frac{\pi}{3}\right)$  (b)  $\sin \frac{7\pi}{6} - \sin \frac{\pi}{3}$

In Exercises 7–22, find the exact values of the sine, cosine, and tangent of the angle.

7.  $105^\circ = 60^\circ + 45^\circ$  8.  $165^\circ = 135^\circ + 30^\circ$

9.  $195^\circ = 225^\circ - 30^\circ$  10.  $285^\circ = 330^\circ - 45^\circ$

11.  $\frac{11\pi}{12} = \frac{3\pi}{4} + \frac{\pi}{6}$  12.  $\frac{17\pi}{12} = \frac{7\pi}{6} + \frac{\pi}{4}$

13.  $-\frac{\pi}{12} = \frac{\pi}{6} - \frac{\pi}{4}$  14.  $-\frac{19\pi}{12} = \frac{2\pi}{3} - \frac{9\pi}{4}$

15.  $75^\circ$  16.  $15^\circ$

17.  $-225^\circ$  18.  $-105^\circ$

19.  $\frac{13\pi}{12}$  20.  $\frac{5\pi}{12}$

21.  $-\frac{7\pi}{12}$  22.  $-\frac{13\pi}{12}$

In Exercises 23–30, write the expression as the sine, cosine, or tangent of an angle.

23.  $\cos 60^\circ \cos 10^\circ - \sin 60^\circ \sin 10^\circ$

24.  $\sin 110^\circ \cos 80^\circ + \cos 110^\circ \sin 80^\circ$

25.  $\frac{\tan 325^\circ - \tan 86^\circ}{1 + \tan 325^\circ \tan 86^\circ}$  26.  $\frac{\tan 152^\circ - \tan 47^\circ}{1 + \tan 152^\circ \tan 47^\circ}$

27.  $\sin 3.5 \cos 1.2 - \cos 3.5 \sin 1.2$

28.  $\cos 0.88 \cos 0.34 + \sin 0.88 \sin 0.34$

29.  $\cos \frac{\pi}{7} \cos \frac{\pi}{5} - \sin \frac{\pi}{7} \sin \frac{\pi}{5}$

30.  $\sin \frac{4\pi}{9} \cos \frac{\pi}{8} + \cos \frac{4\pi}{9} \sin \frac{\pi}{8}$

**Numerical, Graphical, and Algebraic Analysis** In Exercises 31–34, use a graphing utility to complete the table and graph the two functions in the same viewing window. Use both the table and the graph as evidence that  $y_1 = y_2$ . Then verify the identity algebraically.

x	0.2	0.4	0.6	0.8	1.0	1.2	1.4
$y_1$							
$y_2$							

31.  $y_1 = \sin\left(\frac{\pi}{6} + x\right)$ ,  $y_2 = \frac{1}{2}(\cos x + \sqrt{3} \sin x)$

32.  $y_1 = \cos\left(\frac{5\pi}{4} - x\right)$ ,  $y_2 = -\frac{\sqrt{2}}{2}(\cos x + \sin x)$

33.  $y_1 = \cos(x + \pi)\cos(x - \pi)$ ,  $y_2 = \cos^2 x$

34.  $y_1 = \sin(x + \pi)\sin(x - \pi)$ ,  $y_2 = \sin^2 x$

In Exercises 35–38, find the exact value of the trigonometric function given that  $\sin u = \frac{5}{13}$  and  $\cos v = -\frac{3}{5}$ . (Both  $u$  and  $v$  are in Quadrant II.)

35.  $\sin(u + v)$  36.  $\cos(v - u)$

37.  $\tan(u + v)$  38.  $\sin(u - v)$

In Exercises 39–42, find the exact value of the trigonometric function given that  $\sin u = -\frac{7}{25}$  and  $\cos v = -\frac{4}{5}$ . (Both  $u$  and  $v$  are in Quadrant III.)

39.  $\cos(u + v)$  40.  $\tan(u + v)$

41.  $\sin(v - u)$  42.  $\cos(u - v)$

In Exercises 43–46, write the trigonometric expression as an algebraic expression.

43.  $\sin(\arcsin x + \arccos x)$

44.  $\cos(\arccos x - \arcsin x)$

45.  $\sin(\arctan 2x - \arccos x)$

46.  $\cos(\arcsin x - \arctan 2x)$

In Exercises 47–54, verify the identity.

47.  $\sin\left(\frac{\pi}{2} + x\right) = \cos x$       48.  $\sin(3\pi - x) = \sin x$

49.  $\tan(x + \pi) - \tan(\pi - x) = 2 \tan x$

50.  $\tan\left(\frac{\pi}{4} - \theta\right) = \frac{1 - \tan \theta}{1 + \tan \theta}$

51.  $\sin(x + y) + \sin(x - y) = 2 \sin x \cos y$

52.  $\cos(x + y) + \cos(x - y) = 2 \cos x \cos y$

53.  $\cos(x + y) \cos(x - y) = \cos^2 x - \sin^2 y$

54.  $\sin(x + y) \sin(x - y) = \sin^2 x - \sin^2 y$

In Exercises 55–58, find the solutions of the equation in the interval  $[0, 2\pi)$ . Use a graphing utility to verify your results.

55.  $\sin\left(x + \frac{\pi}{3}\right) + \sin\left(x - \frac{\pi}{3}\right) = 1$

56.  $\cos\left(x + \frac{\pi}{4}\right) - \cos\left(x - \frac{\pi}{4}\right) = 1$

57.  $\tan(x + \pi) + 2 \sin(x + \pi) = 0$

58.  $2 \sin\left(x + \frac{\pi}{2}\right) + 3 \tan(\pi - x) = 0$

In Exercises 59–62, use a graphing utility to approximate the solutions of the equation in the interval  $[0, 2\pi)$ .

59.  $\cos\left(x + \frac{\pi}{4}\right) + \cos\left(x - \frac{\pi}{4}\right) = 1$

60.  $\sin\left(x + \frac{\pi}{2}\right) - \cos\left(x + \frac{3\pi}{2}\right) = 0$

61.  $\tan(x + \pi) - \cos\left(x + \frac{\pi}{2}\right) = 0$

62.  $\tan(\pi - x) + 2 \cos\left(x + \frac{3\pi}{2}\right) = 0$

63. **Standing Waves** The equation of a standing wave is obtained by adding the displacements of two waves traveling in opposite directions (see figure).

Assume that each of the waves has amplitude  $A$ , period  $T$ , and wavelength  $\lambda$ . If the models for these waves are

$$y_1 = A \cos 2\pi\left(\frac{t}{T} - \frac{x}{\lambda}\right) \text{ and } y_2 = A \cos 2\pi\left(\frac{t}{T} + \frac{x}{\lambda}\right)$$

show that

$$y_1 + y_2 = 2A \cos \frac{2\pi t}{T} \cos \frac{2\pi x}{\lambda}$$

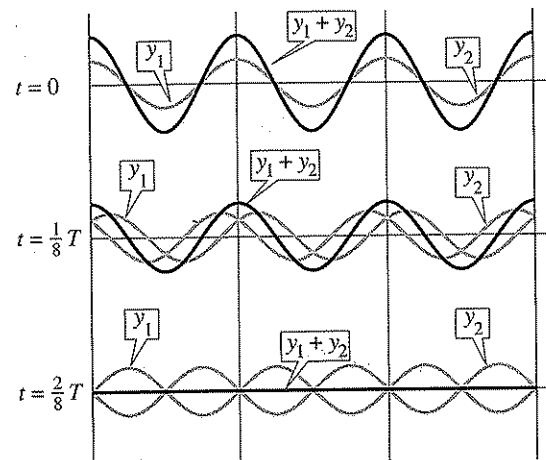

Figure for 63

64. **Harmonic Motion** A weight is attached to a spring suspended vertically from a ceiling. When a driving force is applied to the system, the weight moves vertically from its equilibrium position, and this motion is modeled by

$$y = \frac{1}{3} \sin 2t + \frac{1}{4} \cos 2t$$

where  $y$  is the distance from equilibrium (in feet) and  $t$  is the time (in seconds).

(a) Use a graphing utility to graph the model.

(b) Use the identity

$$a \sin B\theta + b \cos B\theta = \sqrt{a^2 + b^2} \sin(B\theta + C)$$

where  $C = \arctan(b/a)$ ,  $a > 0$ , to write the model in the form

$$y = \sqrt{a^2 + b^2} \sin(Bt + C).$$

Use a graphing utility to verify your result.

(c) Find the amplitude of the oscillations of the weight.

(d) Find the frequency of the oscillations of the weight.

**Synthesis**

**True or False?** In Exercises 65 and 66, determine whether the statement is true or false. Justify your answer.

65.  $\cos(u \pm v) = \cos u \pm \cos v$

66.  $\sin\left(x - \frac{11\pi}{2}\right) = \cos x$

In Exercises 67–70, verify the identity.

67.  $\cos(n\pi + \theta) = (-1)^n \cos \theta$ ,  $n$  is an integer.

68.  $\sin(n\pi + \theta) = (-1)^n \sin \theta$ ,  $n$  is an integer.

69.  $a \sin B\theta + b \cos B\theta = \sqrt{a^2 + b^2} \sin(B\theta + C)$ ,  
where  $C = \arctan(b/a)$  and  $a > 0$ .

70.  $a \sin B\theta + b \cos B\theta = \sqrt{a^2 + b^2} \cos(B\theta - C)$ ,  
where  $C = \arctan(a/b)$  and  $b > 0$ .

In Exercises 71–74, use the formulas given in Exercises 69 and 70 to write the expression in the following forms. Use a graphing utility to verify your results.

(a)  $\sqrt{a^2 + b^2} \sin(B\theta + C)$

(b)  $\sqrt{a^2 + b^2} \cos(B\theta - C)$

71.  $\sin \theta + \cos \theta$

72.  $3 \sin 2\theta + 4 \cos 2\theta$

73.  $12 \sin 3\theta + 5 \cos 3\theta$

74.  $\sin 2\theta - \cos 2\theta$

In Exercises 75 and 76, use the formulas given in Exercises 69 and 70 to write the trigonometric expression in the form  $a \sin B\theta + b \cos B\theta$ .

75.  $2 \sin\left(\theta + \frac{\pi}{2}\right)$

76.  $5 \cos\left(\theta + \frac{\pi}{4}\right)$

**¶** 77. Verify the following identity used in calculus.

$$\frac{\cos(x+h) - \cos x}{h} = \frac{\cos x(\cos h - 1)}{h} - \frac{\sin x \sin h}{h}$$

**¶** 78. **Exploration** Let  $x = \pi/6$  in the identity in Exercise 77 and define the functions  $f$  and  $g$  as follows.

$$f(h) = \frac{\cos(\pi/6 + h) - \cos(\pi/6)}{h}$$

$$g(h) = \cos \frac{\pi}{6} \left( \frac{\cos h - 1}{h} \right) - \sin \frac{\pi}{6} \left( \frac{\sin h}{h} \right)$$

(a) What are the domains of the functions  $f$  and  $g$ ?

(b) Use a graphing utility to complete the table.

$h$	0.01	0.02	0.05	0.1	0.2	0.5
$f(h)$						
$g(h)$						

(c) Use a graphing utility to graph the functions  $f$  and  $g$ .

(d) Use the table and graph to make a conjecture about the values of the functions  $f$  and  $g$  as  $h \rightarrow 0$ .

79. **Conjecture** Three squares of side  $s$  are placed side by side (see figure). Make a conjecture about the relationship between the sum  $u + v + w$  and  $w$ . Prove your conjecture by using the identity for the tangent of the sum of two angles.

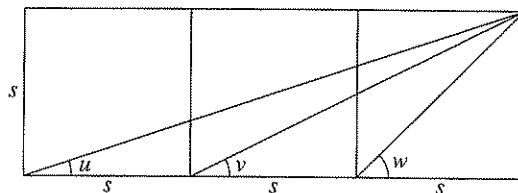

80. (a) Write a sum formula for  $\sin(u + v + w)$ .

(b) Write a sum formula for  $\tan(u + v + w)$ .

**Review**

In Exercises 81–84, find the  $x$ - and  $y$ -intercepts of the graph of the equation. Use a graphing utility to verify your results.

81.  $y = -\frac{1}{2}(x - 10) + 14$

82.  $y = x^2 - 3x - 40$

83.  $y = |2x - 9| - 5$

84.  $y = 2x\sqrt{x+7}$

In Exercises 85–88, evaluate the expression without using a calculator.

85.  $\arccos\left(\frac{\sqrt{3}}{2}\right)$

86.  $\arctan(-\sqrt{3})$

87.  $\sin^{-1} 1$

88.  $\tan^{-1} 0$

## 5.5 Multiple-Angle and Product-to-Sum Formulas

### Multiple-Angle Formulas

In this section you will study four additional categories of trigonometric identities.

1. The first category involves *functions of multiple angles* such as  $\sin ku$  and  $\cos ku$ .
2. The second category involves *squares of trigonometric functions* such as  $\sin^2 u$ .
3. The third category involves *functions of half-angles* such as  $\sin(u/2)$ .
4. The fourth category involves *products of trigonometric functions* such as  $\sin u \cos v$ .

You should learn the **double-angle formulas** below because they are used most often. See Appendix C for proofs of the double-angle formulas.

#### Double-Angle Formulas

$$\begin{aligned} \sin 2u &= 2 \sin u \cos u & \cos 2u &= \cos^2 u - \sin^2 u \\ \tan 2u &= \frac{2 \tan u}{1 - \tan^2 u} & &= 2 \cos^2 u - 1 \\ & & &= 1 - 2 \sin^2 u \end{aligned}$$

### Example 1 Solving a Multiple-Angle Equation

Solve  $2 \cos x + \sin 2x = 0$ .

#### Solution

Begin by rewriting the equation so that it involves functions of  $x$  (rather than  $2x$ ). Then factor and solve as usual.

$$\begin{aligned} 2 \cos x + \sin 2x &= 0 && \text{Write original equation.} \\ 2 \cos x + 2 \sin x \cos x &= 0 && \text{Double-angle formula} \\ 2 \cos x(1 + \sin x) &= 0 && \text{Factor.} \\ \cos x = 0 & \quad 1 + \sin x = 0 && \text{Set factors equal to zero.} \\ x = \frac{\pi}{2}, \frac{3\pi}{2} & \quad x = \frac{3\pi}{2} && \text{Solutions in } [0, 2\pi) \end{aligned}$$

So, the general solution is

$$x = \frac{\pi}{2} + 2n\pi \quad \text{and} \quad x = \frac{3\pi}{2} + 2n\pi \quad \text{General solution}$$

where  $n$  is an integer. Try verifying this solution graphically.

 **Checkpoint** Now try Exercise 9.

#### What you should learn

- Use multiple-angle formulas to rewrite and evaluate trigonometric functions.
- Use power-reducing formulas to rewrite and evaluate trigonometric functions.
- Use half-angle formulas to rewrite and evaluate trigonometric functions.
- Use product-to-sum and sum-to-product formulas to rewrite and evaluate trigonometric functions.

#### Why you should learn it

You can use a variety of trigonometric formulas to rewrite trigonometric functions in more convenient forms. For instance, Exercise 115 on page 384 shows you how to use a half-angle formula to determine the apex angle of a sound wave cone caused by the speed of an airplane.



NASA-Liaison Agency

### Example 2 Using Double-Angle Formulas to Analyze Graphs

Analyze the graph of  $y = 4 \cos^2 x - 2$  in the interval  $[0, 2\pi]$ .

#### Solution

Using a double-angle formula, you can rewrite the original function as

$$\begin{aligned} y &= 4 \cos^2 x - 2 \\ &= 2(2 \cos^2 x - 1) \\ &= 2 \cos 2x. \end{aligned}$$

Using the techniques discussed in Section 4.5, you can recognize that the graph of this function has an amplitude of 2 and a period of  $\pi$ . The key points in the interval  $[0, \pi]$  are as follows.

Maximum	Intercept	Minimum	Intercept	Maximum
$(0, 2)$	$(\frac{\pi}{4}, 0)$	$(\frac{\pi}{2}, -2)$	$(\frac{3\pi}{4}, 0)$	$(\pi, 2)$

Two cycles of the graph are shown in Figure 5.27.

 **Checkpoint** Now try Exercise 13.

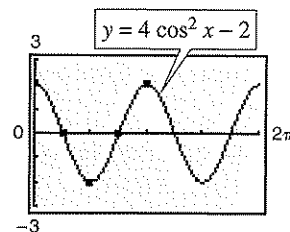

Figure 5.27

### Example 3 Evaluating Functions Involving Double Angles

Use the following to find  $\sin 2\theta$ ,  $\cos 2\theta$ , and  $\tan 2\theta$ .

$$\cos \theta = \frac{5}{13}, \quad \frac{3\pi}{2} < \theta < 2\pi$$

#### Solution

From Figure 5.28, you can see that  $\sin \theta = y/r = -12/13$ . Consequently, using each of the double-angle formulas, you can write

$$\sin 2\theta = 2 \sin \theta \cos \theta = 2 \left( -\frac{12}{13} \right) \left( \frac{5}{13} \right) = -\frac{120}{169}$$

$$\cos 2\theta = 2 \cos^2 \theta - 1 = 2 \left( \frac{25}{169} \right) - 1 = -\frac{119}{169}$$

$$\tan 2\theta = \frac{\sin 2\theta}{\cos 2\theta} = \frac{120}{119}$$

 **Checkpoint** Now try Exercise 17.

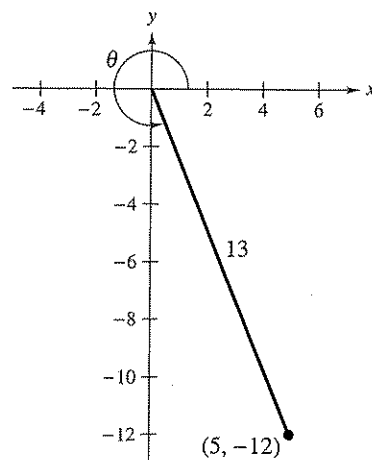

Figure 5.28

The double-angle formulas are not restricted to the angles  $2\theta$  and  $\theta$ . Other *double* combinations, such as  $4\theta$  and  $2\theta$  or  $6\theta$  and  $3\theta$ , are also valid. Here are two examples.

$$\sin 4\theta = 2 \sin 2\theta \cos 2\theta \quad \text{and} \quad \cos 6\theta = \cos^2 3\theta - \sin^2 3\theta$$

By using double-angle formulas together with the sum formulas derived in the preceding section, you can form other multiple-angle formulas.

**Example 4** Deriving a Triple-Angle Formula

$\sin 3x = \sin(2x + x)$	Rewrite as sum.
$= \sin 2x \cos x + \cos 2x \sin x$	Sum formula
$= 2 \sin x \cos x \cos x + (1 - 2 \sin^2 x) \sin x$	Double-angle formula
$= 2 \sin x \cos^2 x + \sin x - 2 \sin^3 x$	Multiply.
$= 2 \sin x(1 - \sin^2 x) + \sin x - 2 \sin^3 x$	Pythagorean identity
$= 2 \sin x - 2 \sin^3 x + \sin x - 2 \sin^3 x$	Multiply.
$= 3 \sin x - 4 \sin^3 x$	Simplify.

**Checkpoint** Now try Exercise 23.

**Power-Reducing Formulas**

The double-angle formulas can be used to obtain the following **power-reducing formulas**. See Appendix C for proofs of the power-reducing formulas.

**Power-Reducing Formulas**

$$\sin^2 u = \frac{1 - \cos 2u}{2} \quad \cos^2 u = \frac{1 + \cos 2u}{2} \quad \tan^2 u = \frac{1 - \cos 2u}{1 + \cos 2u}$$

**Example 5** Reducing a Power

Rewrite  $\sin^4 x$  as a sum of first powers of the cosines of multiple angles.

**Solution**

$\sin^4 x = (\sin^2 x)^2$	Property of exponents
$= \left( \frac{1 - \cos 2x}{2} \right)^2$	Power-reducing formula
$= \frac{1}{4} (1 - 2 \cos 2x + \cos^2 2x)$	Expand binomial.
$= \frac{1}{4} \left( 1 - 2 \cos 2x + \frac{1 + \cos 4x}{2} \right)$	Power-reducing formula
$= \frac{1}{4} - \frac{1}{2} \cos 2x + \frac{1}{8} + \frac{1}{8} \cos 4x$	Distributive Property
$= \frac{3}{8} - \frac{1}{2} \cos 2x + \frac{1}{8} \cos 4x$	Simplify.
$= \frac{1}{8} (3 - 4 \cos 2x + \cos 4x)$	Factor.

**Checkpoint** Now try Exercise 27.

**STUDY TIP**

Power-reducing formulas are often used in calculus. Example 5 shows a typical power reduction that is used in calculus. Note the repeated use of power-reducing formulas.

## Half-Angle Formulas

You can derive some useful alternative forms of the power-reducing formulas by replacing  $u$  with  $u/2$ . The results are called **half-angle formulas**.

### Half-Angle Formulas

$$\sin \frac{u}{2} = \pm \sqrt{\frac{1 - \cos u}{2}} \qquad \cos \frac{u}{2} = \pm \sqrt{\frac{1 + \cos u}{2}}$$

$$\tan \frac{u}{2} = \frac{1 - \cos u}{\sin u} = \frac{\sin u}{1 + \cos u}$$

The signs of  $\sin \frac{u}{2}$  and  $\cos \frac{u}{2}$  depend on the quadrant in which  $\frac{u}{2}$  lies.

### Example 6 Using a Half-Angle Formula

Find the exact value of  $\sin 105^\circ$ .

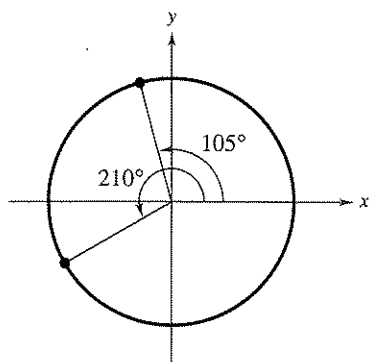

Figure 5.29

#### Solution

Begin by noting that  $105^\circ$  is half of  $210^\circ$ . Then, using the half-angle formula for  $\sin(u/2)$  and the fact that  $105^\circ$  lies in Quadrant II (see Figure 5.29), you have

$$\begin{aligned} \sin 105^\circ &= \sqrt{\frac{1 - \cos 210^\circ}{2}} \\ &= \sqrt{\frac{1 - (-\cos 30^\circ)}{2}} \\ &= \sqrt{\frac{1 + (\sqrt{3}/2)}{2}} = \frac{\sqrt{2 + \sqrt{3}}}{2} \end{aligned}$$

The positive square root is chosen because  $\sin \theta$  is positive in Quadrant II.

**Checkpoint** Now try Exercise 41.

### STUDY TIP

To find the exact value of a trigonometric function with an angle in D°M'S" form using a half-angle formula, first convert the angle measure to decimal degree form. Then multiply the angle measure by 2.

### TECHNOLOGY TIP

Use your calculator to verify the result obtained in Example 6. That is, evaluate  $\sin 105^\circ$  and  $(\sqrt{2 + \sqrt{3}})/2$ . You will notice that both expressions yield the same result.

**Example 7** Solving a Trigonometric Equation

Find all solutions of  $2 - \sin^2 x = 2 \cos^2 \frac{x}{2}$  in the interval  $[0, 2\pi)$ .

**Algebraic Solution**

$$2 - \sin^2 x = 2 \cos^2 \frac{x}{2} \quad \text{Write original equation.}$$

$$2 - \sin^2 x = 2 \left( \pm \sqrt{\frac{1 + \cos x}{2}} \right)^2 \quad \text{Half-angle formula}$$

$$2 - \sin^2 x = 2 \left( \frac{1 + \cos x}{2} \right) \quad \text{Simplify.}$$

$$2 - \sin^2 x = 1 + \cos x \quad \text{Simplify.}$$

$$2 - (1 - \cos^2 x) = 1 + \cos x \quad \text{Pythagorean identity}$$

$$\cos^2 x - \cos x = 0 \quad \text{Simplify.}$$

$$\cos x (\cos x - 1) = 0 \quad \text{Factor.}$$

By setting the factors  $\cos x$  and  $(\cos x - 1)$  equal to zero, you find that the solutions in the interval  $[0, 2\pi)$  are

$$x = \frac{\pi}{2}, \quad x = \frac{3\pi}{2}, \quad \text{and} \quad x = 0.$$

 **Checkpoint** Now try Exercise 59.

**Graphical Solution**

Use a graphing utility set in *radian* mode to graph  $y = 2 - \sin^2 x - 2 \cos^2 (x/2)$ , as shown in Figure 5.30. Use the *zero* or *root* feature or the *zoom* and *trace* features to approximate the  $x$ -intercepts in the interval  $[0, 2\pi)$  to be

$$x = 0, \quad x \approx 1.5708 \approx \frac{\pi}{2}, \quad \text{and} \quad x \approx 4.7124 \approx \frac{3\pi}{2}.$$

These values are the approximate solutions of

$$2 - \sin^2 x = 2 \cos^2 \frac{x}{2} \quad \text{in the interval } [0, 2\pi).$$

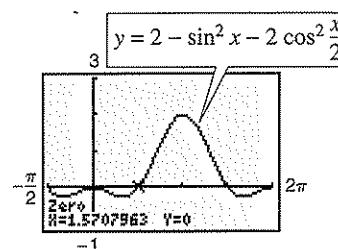

Figure 5.30

**Product-to-Sum Formulas**

Each of the following **product-to-sum formulas** is easily verified using the sum and difference formulas discussed in the preceding section.

**Product-to-Sum Formulas**

$$\sin u \sin v = \frac{1}{2} [\cos(u - v) - \cos(u + v)]$$

$$\cos u \cos v = \frac{1}{2} [\cos(u - v) + \cos(u + v)]$$

$$\sin u \cos v = \frac{1}{2} [\sin(u + v) + \sin(u - v)]$$

$$\cos u \sin v = \frac{1}{2} [\sin(u + v) - \sin(u - v)]$$

Product-to-sum formulas are used in calculus to evaluate integrals involving the products of sines and cosines of two different angles.



**Example 8** Writing Products as Sums

Rewrite the product as a sum or difference.

$$\cos 5x \sin 4x$$

**Solution**

$$\begin{aligned}\cos 5x \sin 4x &= \frac{1}{2}[\sin(5x + 4x) - \sin(5x - 4x)] \\ &= \frac{1}{2} \sin 9x - \frac{1}{2} \sin x\end{aligned}$$

 **Checkpoint** Now try Exercise 65.

Occasionally, it is useful to reverse the procedure and write a sum of trigonometric functions as a product. This can be accomplished with the following **sum-to-product formulas**. See Appendix C for a proof of the first formula.

**Sum-to-Product Formulas**

$$\sin u + \sin v = 2 \sin\left(\frac{u+v}{2}\right) \cos\left(\frac{u-v}{2}\right)$$

$$\sin u - \sin v = 2 \cos\left(\frac{u+v}{2}\right) \sin\left(\frac{u-v}{2}\right)$$

$$\cos u + \cos v = 2 \cos\left(\frac{u+v}{2}\right) \cos\left(\frac{u-v}{2}\right)$$

$$\cos u - \cos v = -2 \sin\left(\frac{u+v}{2}\right) \sin\left(\frac{u-v}{2}\right)$$

**Example 9** Using a Sum-to-Product Formula

Find the exact value of  $\cos 195^\circ + \cos 105^\circ$ .

**Solution**

Using the appropriate sum-to-product formula, you obtain

$$\begin{aligned}\cos 195^\circ + \cos 105^\circ &= 2 \cos\left(\frac{195^\circ + 105^\circ}{2}\right) \cos\left(\frac{195^\circ - 105^\circ}{2}\right) \\ &= 2 \cos 150^\circ \cos 45^\circ \\ &= 2\left(-\frac{\sqrt{3}}{2}\right)\left(\frac{\sqrt{2}}{2}\right) \\ &= -\frac{\sqrt{6}}{2}\end{aligned}$$

 **Checkpoint** Now try Exercise 75.

**TECHNOLOGY TIP**

You can use a graphing utility to verify the solution in Example 8. Graph  $y_1 = \cos 5x \sin 4x$  and  $y_2 = \frac{1}{2} \sin 9x - \frac{1}{2} \sin x$  in the same viewing window. Notice that the graphs coincide. So, you can conclude that the two expressions are equivalent.

**Example 10** Solving a Trigonometric Equation

Find all solutions of  $\sin 5x + \sin 3x = 0$  in the interval  $[0, 2\pi)$ .

**Algebraic Solution**

$$\begin{aligned} \sin 5x + \sin 3x &= 0 && \text{Write original equation.} \\ 2 \sin\left(\frac{5x + 3x}{2}\right) \cos\left(\frac{5x - 3x}{2}\right) &= 0 && \text{Sum-to-product formula} \\ 2 \sin 4x \cos x &= 0 && \text{Simplify.} \end{aligned}$$

By setting the factor  $\sin 4x$  equal to zero, you can find that the solutions in the interval  $[0, 2\pi)$  are

$$x = 0, \frac{\pi}{4}, \frac{\pi}{2}, \frac{3\pi}{4}, \pi, \frac{5\pi}{4}, \frac{3\pi}{2}, \frac{7\pi}{4}.$$

Moreover, the equation  $\cos x = 0$  yields no additional solutions.

 **Checkpoint** Now try Exercise 79.

**Graphical Solution**

Use a graphing utility set in *radian* mode to graph  $y = \sin 5x + \sin 3x$ , as shown in Figure 5.31. Use the *zero* or *root* feature or the *zoom* and *trace* features to approximate the  $x$ -intercepts in the interval  $[0, 2\pi)$  to be

$$x \approx 0, \quad x \approx 0.7854 \approx \frac{\pi}{4}, \quad x \approx 1.5708 \approx \frac{\pi}{2},$$

$$x \approx 2.3562 \approx \frac{3\pi}{4}, \quad x \approx 3.1416 \approx \pi, \quad x \approx 3.9270 \approx \frac{5\pi}{4},$$

$$x \approx 4.7124 \approx \frac{3\pi}{2}, \quad x \approx 5.4978 \approx \frac{7\pi}{4}.$$

These values are the approximate solutions of  $\sin 5x + \sin 3x = 0$  in the interval  $[0, 2\pi)$ .

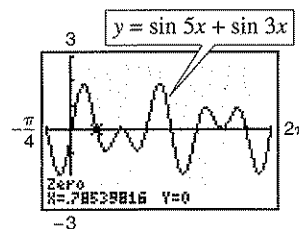

Figure 5.31

Note in Example 10 that the general solution is  $x = \frac{n\pi}{4}$ , where  $n$  is an integer.

**Example 11** Verifying a Trigonometric Identity

Verify the identity  $\frac{\sin t + \sin 3t}{\cos t + \cos 3t} = \tan 2t$ .

**Solution**

Using appropriate sum-to-product formulas, you have

$$\begin{aligned} \frac{\sin t + \sin 3t}{\cos t + \cos 3t} &= \frac{2 \sin 2t \cos(-t)}{2 \cos 2t \cos(-t)} \\ &= \frac{\sin 2t}{\cos 2t} \\ &= \tan 2t. \end{aligned}$$

 **Checkpoint** Now try Exercise 97.

## 5.5 Exercises

## Vocabulary Check

Fill in the blank to complete the trigonometric formula.

1.  $\sin 2u =$  \_\_\_\_\_

2.  $\cos^2 u =$  \_\_\_\_\_

3. \_\_\_\_\_  $= 1 - 2 \sin^2 u$

4. \_\_\_\_\_  $= \frac{\sin u}{1 + \cos u}$

5.  $\tan 2u =$  \_\_\_\_\_

6.  $\cos u \cos v =$  \_\_\_\_\_

7. \_\_\_\_\_  $= \frac{1 - \cos 2u}{2}$

8. \_\_\_\_\_  $= \pm \sqrt{\frac{1 + \cos u}{2}}$

9.  $\sin u \cos v =$  \_\_\_\_\_

10.  $\sin u + \sin v =$  \_\_\_\_\_

In Exercises 1–8, use the figure to find the exact value of the trigonometric function.

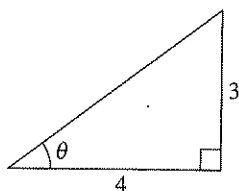

- |                   |                   |
|-------------------|-------------------|
| 1. $\sin \theta$  | 2. $\cos \theta$  |
| 3. $\cos 2\theta$ | 4. $\sin 2\theta$ |
| 5. $\tan 2\theta$ | 6. $\sec 2\theta$ |
| 7. $\csc 2\theta$ | 8. $\cot 2\theta$ |

In Exercises 9–16, use a graphing utility to approximate the solutions of the equation in the interval  $[0, 2\pi)$ . If possible, find the exact solutions algebraically.

- |                            |                                 |
|----------------------------|---------------------------------|
| 9. $\sin 2x - \sin x = 0$  | 10. $\sin 2x + \cos x = 0$      |
| 11. $4 \sin x \cos x = 1$  | 12. $\sin 2x \sin x = \cos x$   |
| 13. $\cos 2x - \cos x = 0$ | 14. $\tan 2x - \cot x = 0$      |
| 15. $\sin 4x = -2 \sin 2x$ | 16. $(\sin 2x + \cos 2x)^2 = 1$ |

In Exercises 17–22, find the exact values of  $\sin 2u$ ,  $\cos 2u$ , and  $\tan 2u$  using the double-angle formulas.

17.  $\sin u = \frac{3}{5}$ ,  $0 < u < \pi/2$
18.  $\cos u = -\frac{2}{7}$ ,  $\pi/2 < u < \pi$
19.  $\tan u = \frac{1}{2}$ ,  $\pi < u < 3\pi/2$
20.  $\cot u = -6$ ,  $3\pi/2 < u < 2\pi$
21.  $\sec u = -\frac{5}{2}$ ,  $\pi/2 < u < \pi$
22.  $\csc u = 3$ ,  $\pi/2 < u < \pi$

In Exercises 23–26, use a double-angle formula to rewrite the expression. Use a graphing utility to graph both expressions to verify that both forms are the same.

23.  $8 \sin x \cos x$
24.  $4 \sin x \cos x + 1$
25.  $6 - 12 \sin^2 x$
26.  $(\cos x + \sin x)(\cos x - \sin x)$

In Exercises 27–32, rewrite the expression in terms of the first power of the cosine. Use a graphing utility to graph both expressions to verify that both forms are the same.

27.  $\cos^4 x$
28.  $\sin^4 x$
29.  $\sin^2 x \cos^2 x$
30.  $\cos^6 x$
31.  $\sin^2 x \cos^4 x$
32.  $\sin^4 x \cos^2 x$

In Exercises 33–40, use the figure to find the exact value of the trigonometric function.

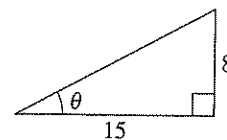

33.  $\cos \frac{\theta}{2}$
34.  $\sin \frac{\theta}{2}$
35.  $\tan \frac{\theta}{2}$
36.  $\sec \frac{\theta}{2}$
37.  $\csc \frac{\theta}{2}$
38.  $\cot \frac{\theta}{2}$
39.  $2 \sin \frac{\theta}{2} \cos \frac{\theta}{2}$
40.  $2 \cos \frac{\theta}{2} \tan \frac{\theta}{2}$

In Exercises 41–48, use the half-angle formulas to determine the exact values of the sine, cosine, and tangent of the angle.

41.  $15^\circ$                       42.  $165^\circ$   
 43.  $112^\circ 30'$                 44.  $157^\circ 30'$   
 45.  $\frac{\pi}{8}$                             46.  $\frac{\pi}{12}$   
 47.  $\frac{3\pi}{8}$                           48.  $\frac{7\pi}{12}$

In Exercises 49–54, find the exact values of  $\sin(u/2)$ ,  $\cos(u/2)$ , and  $\tan(u/2)$  using the half-angle formulas.

49.  $\sin u = \frac{5}{13}$ ,  $\pi/2 < u < \pi$   
 50.  $\cos u = \frac{7}{25}$ ,  $0 < u < \pi/2$   
 51.  $\tan u = -\frac{8}{5}$ ,  $3\pi/2 < u < 2\pi$   
 52.  $\cot u = 7$ ,  $\pi < u < 3\pi/2$   
 53.  $\csc u = -\frac{5}{3}$ ,  $\pi < u < 3\pi/2$   
 54.  $\sec u = -\frac{7}{2}$ ,  $\pi/2 < u < \pi$

In Exercises 55–58, use the half-angle formulas to simplify the expression.

55.  $\sqrt{\frac{1 - \cos 6x}{2}}$                 56.  $\sqrt{\frac{1 + \cos 4x}{2}}$   
 57.  $-\sqrt{\frac{1 - \cos 8x}{1 + \cos 8x}}$         58.  $-\sqrt{\frac{1 - \cos(x-1)}{2}}$

In Exercises 59–62, find the solutions of the equation in the interval  $[0, 2\pi)$ . Use a graphing utility to verify your answers.

59.  $\sin \frac{x}{2} - \cos x = 0$   
 60.  $\sin \frac{x}{2} + \cos x - 1 = 0$   
 61.  $\cos \frac{x}{2} - \sin x = 0$   
 62.  $\tan \frac{x}{2} - \sin x = 0$

In Exercises 63–68, use the product-to-sum formulas to write the product as a sum or difference.

63.  $6 \sin \frac{\pi}{3} \cos \frac{\pi}{3}$             64.  $4 \sin \frac{\pi}{3} \cos \frac{5\pi}{6}$   
 65.  $\sin 5\theta \cos 3\theta$             66.  $5 \sin 3\alpha \sin 4\alpha$

67.  $5 \cos(-5\beta) \cos 3\beta$         68.  $\cos 2\theta \cos 4\theta$

In Exercises 69–74, use the sum-to-product formulas to write the sum or difference as a product.

69.  $\sin 5\theta - \sin \theta$   
 70.  $\sin x + \sin 7x$   
 71.  $\sin(\alpha + \beta) - \sin(\alpha - \beta)$   
 72.  $\cos(\phi + 2\pi) + \cos \phi$   
 73.  $\cos\left(\theta + \frac{\pi}{2}\right) - \cos\left(\theta - \frac{\pi}{2}\right)$   
 74.  $\sin\left(x + \frac{\pi}{2}\right) + \sin\left(x - \frac{\pi}{2}\right)$

In Exercises 75–78, use the sum-to-product formulas to find the exact value of the expression.

75.  $\sin 195^\circ + \sin 105^\circ$         76.  $\cos 165^\circ - \cos 75^\circ$   
 77.  $\cos \frac{5\pi}{12} + \cos \frac{\pi}{12}$         78.  $\sin \frac{11\pi}{12} - \sin \frac{7\pi}{12}$

In Exercises 79–82, find the solutions of the equation in the interval  $[0, 2\pi)$ . Use a graphing utility to verify your answers.

79.  $\sin 6x + \sin 2x = 0$   
 80.  $\cos 2x - \cos 6x = 0$   
 81.  $\frac{\cos 2x}{\sin 3x - \sin x} - 1 = 0$   
 82.  $\sin^2 3x - \sin^2 x = 0$

In Exercises 83–86, use the figure and trigonometric identities to find the exact value of the trigonometric function in two ways.

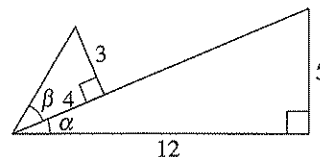

83.  $\sin^2 \alpha$                       84.  $\cos^2 \alpha$   
 85.  $\sin \alpha \cos \beta$               86.  $\cos \alpha \sin \beta$

In Exercises 87–98, verify the identity algebraically. Use a graphing utility to check your result graphically.

87.  $\csc 2\theta = \frac{\csc \theta}{2 \cos \theta}$         88.  $\sec 2\theta = \frac{\sec^2 \theta}{2 - \sec^2 \theta}$

89.  $\cos^2 2\alpha - \sin^2 2\alpha = \cos 4\alpha$

90.  $\cos^4 x - \sin^4 x = \cos 2x$

91.  $(\sin x + \cos x)^2 = 1 + \sin 2x$

92.  $1 + \cos 10y = 2 \cos^2 5y$

93.  $\sec \frac{u}{2} = \pm \sqrt{\frac{2 \tan u}{\tan u + \sin u}}$

94.  $\tan \frac{u}{2} = \csc u - \cot u$

95.  $\cos 3\beta = \cos^3 \beta - 3 \sin^2 \beta \cos \beta$

96.  $\sin 4\beta = 4 \sin \beta \cos \beta (1 - 2 \sin^2 \beta)$

97.  $\frac{\cos 4x - \cos 2x}{2 \sin 3x} = -\sin x$

98.  $\frac{\cos 3x - \cos x}{\sin 3x - \sin x} = -\tan 2x$

In Exercises 99–102, graph the function by using the power-reducing formulas.

99.  $f(x) = \sin^2 x$

100.  $f(x) = \cos^2 x$

101.  $f(x) = \cos^4 x$

102.  $f(x) = \sin^3 x$

**f** In Exercises 103–106, (a) use a graphing utility to graph the function and approximate the maximum and minimum points of the graph in the interval  $[0, 2\pi]$ , and (b) solve the trigonometric equation and verify that the  $x$ -coordinates of the maximum and minimum points of  $f$  are among its solutions (calculus is required to find the trigonometric equation).

Function	Trigonometric Equation
103. $f(x) = 4 \sin \frac{x}{2} + \cos x$	$2 \cos \frac{x}{2} - \sin x = 0$
104. $f(x) = \cos 2x - 2 \sin x$	$-2 \cos x (2 \sin x + 1) = 0$
105. $f(x) = 2 \cos \frac{x}{2} + \sin 2x$	$2 \cos 2x - \sin \frac{x}{2} = 0$
106. $f(x) = 2 \sin \frac{x}{2} - 5 \cos \left(2x - \frac{\pi}{4}\right)$	$10 \sin \left(2x - \frac{\pi}{4}\right) + \cos \frac{x}{2} = 0$

In Exercises 107–112, write the trigonometric expression as an algebraic expression.

107.  $\sin(2 \arcsin x)$

108.  $\cos(2 \arccos x)$

109.  $\cos(2 \arcsin x)$

110.  $\sin(2 \arccos x)$

111.  $\cos(2 \arctan x)$

112.  $\sin(2 \arctan x)$

**113. Projectile Motion** The range of a projectile fired at an angle  $\theta$  with the horizontal and with an initial velocity of  $v_0$  feet per second is given by

$$r = \frac{1}{32} v_0^2 \sin 2\theta$$

where  $r$  is measured in feet. Rewrite the expression for the range in terms of  $\theta$ .

**114. Geometry** The length of each of the two equal sides of an isosceles triangle is 10 meters (see figure). The angle between the two sides is  $\theta$ .

(a) Write the area of the triangle as a function of  $\theta/2$ .

(b) Write the area of the triangle as a function of  $\theta$  and determine the value of  $\theta$  such that the area is a maximum.

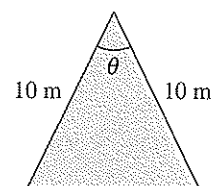

**115. Mach Number** The mach number  $M$  of an airplane is the ratio of its speed to the speed of sound. When an airplane travels faster than the speed of sound, the sound waves form a cone behind the airplane (see figure). The mach number is related to the apex angle  $\theta$  of the cone by

$$\sin \frac{\theta}{2} = \frac{1}{M}$$

(a) Find the angle  $\theta$  that corresponds to a mach number of 1.

(b) Find the angle  $\theta$  that corresponds to a mach number of 4.5.

(c) The speed of sound is about 760 miles per hour. Determine the speed of an object having the mach numbers in parts (a) and (b).

(d) Rewrite the equation as a trigonometric function of  $\theta$ .

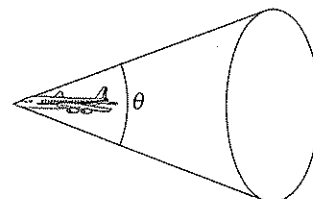

- 116. Railroad Track** When two railroad tracks merge, the overlapping portions of the tracks are in the shape of a circular arc (see figure). The radius of each arc  $r$  (in feet) and the angle  $\theta$  are related by

$$\frac{x}{2} = 2r \sin^2 \frac{\theta}{2}.$$

Write a formula for  $x$  in terms of  $\cos \theta$ .

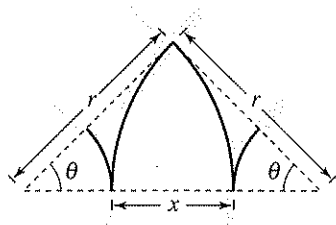

### Synthesis

**True or False?** In Exercises 117 and 118, determine whether the statement is true or false. Justify your answer.

117.  $\sin \frac{x}{2} = -\sqrt{\frac{1 - \cos x}{2}}, \quad \pi \leq x \leq 2\pi$

118. The graph of  $y = 4 - 8 \sin^2 x$  has a maximum at  $(\pi, 4)$ .

119. **Conjecture** Consider the function

$$f(x) = 2 \sin x \left( 2 \cos^2 \frac{x}{2} - 1 \right).$$

- (a) Use a graphing utility to graph the function.  
 (b) Make a conjecture about the function that is an identity with  $f$ .  
 (c) Verify your conjecture algebraically.

120. **Exploration** Consider the function

$$f(x) = \sin^4 x + \cos^4 x.$$

- (a) Use the power-reducing formulas to write the function in terms of cosine to the first power.  
 (b) Determine another way of rewriting the function. Use a graphing utility to rule out incorrectly rewritten functions.  
 (c) Add a trigonometric term to the function so that it becomes a perfect square trinomial. Rewrite the function as a perfect square trinomial minus the term that you added. Use a graphing utility to rule out incorrectly rewritten functions.

- (d) Rewrite the result of part (c) in terms of the sine of a double angle. Use a graphing utility to rule out incorrectly rewritten functions.

- (e) When you rewrite a trigonometric expression, the result may not be the same as a friend's. Does this mean that one of you is wrong? Explain.

121. **Writing** Describe how you can use a double-angle formula or a half-angle formula to derive a formula for the area of an isosceles triangle. Use a labeled sketch to illustrate your derivation. Then write two examples that show how your formula can be used.

122. (a) Write a formula for  $\cos 3\theta$ .  
 (b) Write a formula for  $\cos 4\theta$ .

### Review

In Exercises 123–126, (a) plot the points, (b) find the distance between the points, and (c) find the midpoint of the line segment connecting the points.

123.  $(5, 2), (-1, 4)$       124.  $(-4, -3), (6, 10)$   
 125.  $(0, \frac{1}{2}), (\frac{4}{3}, \frac{5}{2})$       126.  $(\frac{1}{3}, \frac{2}{3}), (-1, -\frac{3}{2})$

In Exercises 127–130, find (if possible) the complement and supplement of each angle.

127. (a)  $55^\circ$       (b)  $162^\circ$   
 128. (a)  $109^\circ$       (b)  $78^\circ$   
 129. (a)  $\frac{\pi}{18}$       (b)  $\frac{9\pi}{20}$   
 130. (a)  $0.95$       (b)  $2.76$

131. Find the radian measure of the central angle of a circle with a radius of 15 inches that intercepts an arc of length 7 inches.

132. Find the length of the arc on a circle of radius 21 centimeters intercepted by a central angle of  $35^\circ$ .

In Exercises 133–136, sketch a graph of the function. (Include two full periods.) Use a graphing utility to verify your graph.

133.  $f(x) = \frac{3}{2} \cos 2x$       134.  $f(x) = \frac{5}{2} \sin \frac{1}{2}x$   
 135.  $f(x) = \frac{1}{2} \tan 2\pi x$       136.  $f(x) = \frac{1}{4} \sec \frac{\pi x}{2}$

## 5 Chapter Summary

### What did you learn?

#### Section 5.1

- Recognize and write the fundamental trigonometric identities.
- Use the fundamental trigonometric identities to evaluate trigonometric functions, simplify trigonometric expressions, and rewrite trigonometric expressions.

#### Review Exercises

1–10

11–24

#### Section 5.2

- Verify trigonometric identities.

25–36

#### Section 5.3

- Use standard algebraic techniques to solve trigonometric equations.
- Solve trigonometric equations of quadratic type.
- Solve trigonometric equations involving multiple angles.
- Use inverse trigonometric functions to solve trigonometric equations.

37–48

49–52

53–58

59–62

#### Section 5.4

- Use sum and difference formulas to evaluate trigonometric functions, verify identities, and solve trigonometric equations.

63–84

#### Section 5.5

- Use multiple-angle formulas to rewrite and evaluate trigonometric functions.
- Use power-reducing formulas to rewrite and evaluate trigonometric functions.
- Use half-angle formulas to rewrite and evaluate trigonometric functions.
- Use product-to-sum and sum-to-product formulas to rewrite and evaluate trigonometric functions.

85–94

95–98

99–110

111–122

## 5 Review Exercises

**5.1** In Exercises 1–10, name the trigonometric function equivalent to the expression.

- $\frac{1}{\cos x}$
- $\frac{1}{\sin x}$
- $\frac{1}{\sec x}$
- $\frac{1}{\tan x}$
- $\sqrt{1 - \cos^2 x}$
- $\sqrt{1 + \tan^2 x}$
- $\csc\left(\frac{\pi}{2} - x\right)$
- $\cot\left(\frac{\pi}{2} - x\right)$
- $\sec(-x)$
- $\tan(-x)$

In Exercises 11–14, use the given values to evaluate (if possible) all six trigonometric functions of the angle.

- $\sin x = \frac{4}{5}, \quad \cos x = \frac{3}{5}$
- $\tan \theta = \frac{2}{3}, \quad \sec \theta = \frac{\sqrt{13}}{3}$
- $\sin\left(\frac{\pi}{2} - x\right) = \frac{1}{\sqrt{2}}, \quad \sin x = -\frac{1}{\sqrt{2}}$
- $\csc\left(\frac{\pi}{2} - \theta\right) = 3, \quad \sin \theta = \frac{2\sqrt{2}}{3}$

In Exercises 15–22, use the fundamental identities to simplify the expression. Use the *table* feature of a graphing utility to check your result numerically.

- $\frac{1}{\cot^2 x + 1}$
- $\frac{\sec^2 x - 1}{\sec x - 1}$
- $\frac{\sin^2 \alpha - \cos^2 \alpha}{\sin^2 \alpha - \sin \alpha \cos \alpha}$
- $\frac{\sin^3 \beta + \cos^3 \beta}{\sin \beta + \cos \beta}$
- $\tan^2 \theta (\csc^2 \theta - 1)$
- $\csc^2 x (1 - \cos^2 x)$
- $\tan\left(\frac{\pi}{2} - x\right) \sec x$
- $\frac{\sin(-x) \cot x}{\sin\left(\frac{\pi}{2} - x\right)}$

**23. Rate of Change** The rate of change of the function  $f(x) = 2\sqrt{\sin x}$  is given by the expression  $\sin^{-1/2} x \cos x$ . Show that this expression can also be written as  $\cot x \sqrt{\sin x}$ .

**24. Rate of Change** The rate of change of the function  $f(x) = \csc x - \cot x$  is the expression  $\csc^2 x - \csc x \cot x$ . Show that this expression can also be written as  $(1 - \cos x)/\sin^2 x$ .

**5.2** In Exercises 25–36, verify the identity.

- $\cos x(\tan^2 x + 1) = \sec x$
- $\sec^2 x \cot x - \cot x = \tan x$
- $\sin^3 \theta + \sin \theta \cos^2 \theta = \sin \theta$
- $\cot^2 x - \cos^2 x = \cot^2 x \cos^2 x$
- $\sin^5 x \cos^2 x = (\cos^2 x - 2 \cos^4 x + \cos^6 x) \sin x$
- $\cos^3 x \sin^2 x = (\sin^2 x - \sin^4 x) \cos x$
- $\sqrt{\frac{1 - \sin \theta}{1 + \sin \theta}} = \frac{1 - \sin \theta}{|\cos \theta|}$
- $\sqrt{1 - \cos x} = \frac{|\sin x|}{\sqrt{1 + \cos x}}$
- $\frac{\csc(-x)}{\sec(-x)} = -\cot x$
- $\frac{1 + \sec(-x)}{\sin(-x) + \tan(-x)} = -\csc x$
- $\sin^2 x + \sin^2\left(\frac{\pi}{2} - x\right) = 1$
- $\csc x \sin\left(\frac{\pi}{2} - x\right) = \cot x$

**5.3** In Exercises 37–48, solve the equation.

- $2 \sin x - 1 = 0$
- $\tan x + 1 = 0$
- $\sin x = \sqrt{3} - \sin x$
- $4 \cos x = 1 + 2 \cos x$
- $3\sqrt{3} \tan x = 3$
- $\frac{1}{2} \sec x - 1 = 0$
- $3 \csc^2 x = 4$
- $4 \tan^2 x - 1 = \tan^2 x$
- $4 \cos^2 x - 3 = 0$
- $\sin x(\sin x + 1) = 0$
- $\sin x - \tan x = 0$
- $\csc x - 2 \cot x = 0$

In Exercises 49–58, find all solutions of the equation in the interval  $[0, 2\pi)$ . Use a graphing utility to check your answers.

- $2 \cos^2 x - \cos x = 1$
- $2 \sin^2 x - 3 \sin x = -1$
- $\cos^2 x + \sin x = 1$
- $\sin^2 x + 2 \cos x = 2$
- $2 \sin 2x - \sqrt{2} = 0$
- $\sqrt{3} \tan 3x = 0$
- $\cos 4x(\cos x - 1) = 0$
- $3 \csc^2 5x = -4$



57.  $\cos 4x - 7 \cos 2x = 8$     58.  $\sin 4x - \sin 2x = 0$

In Exercises 59–62, use the inverse functions where necessary to find all solutions of the equation in the interval  $[0, 2\pi)$ .

59.  $\sin^2 x - 2 \sin x = 0$

60.  $2 \cos^2 x + 3 \cos x = 0$

61.  $\tan^2 \theta + \tan \theta - 12 = 0$

62.  $\sec^2 x + 6 \tan x + 4 = 0$

5.4 In Exercises 63–66, find the exact values of the sine, cosine, and tangent of the angle.

63.  $285^\circ = 315^\circ - 30^\circ$     64.  $345^\circ = 300^\circ + 45^\circ$

65.  $\frac{25\pi}{12} = \frac{11\pi}{6} + \frac{\pi}{4}$     66.  $\frac{19\pi}{12} = \frac{11\pi}{6} - \frac{\pi}{4}$

In Exercises 67–70, write the expression as the sine, cosine, or tangent of an angle.

67.  $\sin 140^\circ \cos 50^\circ + \cos 140^\circ \sin 50^\circ$

68.  $\cos 45^\circ \cos 120^\circ - \sin 45^\circ \sin 120^\circ$

69.  $\frac{\tan 25^\circ + \tan 10^\circ}{1 - \tan 25^\circ \tan 10^\circ}$     70.  $\frac{\tan 68^\circ - \tan 115^\circ}{1 + \tan 68^\circ \tan 115^\circ}$

In Exercises 71–76, find the exact value of the trigonometric function given that  $\sin u = \frac{3}{4}$  and  $\cos v = -\frac{5}{13}$ . (Both  $u$  and  $v$  are in Quadrant II.)

71.  $\sin(u + v)$     72.  $\tan(u + v)$

73.  $\tan(u - v)$     74.  $\sin(u - v)$

75.  $\cos(u + v)$     76.  $\cos(u - v)$

In Exercises 77–82, verify the identity.

77.  $\cos\left(x + \frac{\pi}{2}\right) = -\sin x$     78.  $\sin\left(x - \frac{3\pi}{2}\right) = \cos x$

79.  $\cot\left(\frac{\pi}{2} - x\right) = \tan x$     80.  $\sin(\pi - x) = \sin x$

81.  $\cos 3x = 4 \cos^3 x - 3 \cos x$

82.  $\frac{\sin(\alpha + \beta)}{\cos \alpha \cos \beta} = \tan \alpha + \tan \beta$

In Exercises 83 and 84, find the solutions of the equation in the interval  $[0, 2\pi)$ .

83.  $\sin\left(x + \frac{\pi}{2}\right) - \sin\left(x - \frac{\pi}{2}\right) = \sqrt{3}$

84.  $\cos\left(x + \frac{3\pi}{4}\right) - \cos\left(x - \frac{3\pi}{4}\right) = 0$

5.5 In Exercises 85–88, find the exact values of  $\sin 2u$ ,  $\cos 2u$ , and  $\tan 2u$  using the double-angle formulas.

85.  $\sin u = -\frac{5}{7}, \quad \pi < u < \frac{3\pi}{2}$

86.  $\cos u = \frac{4}{5}, \quad \frac{3\pi}{2} < u < 2\pi$

87.  $\tan u = -\frac{2}{9}, \quad \frac{\pi}{2} < u < \pi$

88.  $\cos u = -\frac{2}{\sqrt{5}}, \quad \frac{\pi}{2} < u < \pi$

In Exercises 89–92, use double-angle formulas to verify the identity algebraically. Use a graphing utility to check your result graphically.

89.  $6 \sin x \cos x = 3 \sin 2x$

90.  $4 \sin x \cos x + 2 = 2 \sin 2x + 2$

91.  $1 - 4 \sin^2 x \cos^2 x = \cos^2 2x$

92.  $\sin 4x = 8 \cos^3 x \sin x - 4 \cos x \sin x$

93. **Projectile Motion** A baseball leaves the hand of the first baseman at an angle of  $\theta$  with the horizontal and with an initial velocity of  $v_0 = 80$  feet per second. The ball is caught by the second baseman 100 feet away. Find  $\theta$  if the range  $r$  of a projectile is given by  $r = \frac{1}{32} v_0^2 \sin 2\theta$ .

94. **Projectile Motion** Use the equation in Exercise 93 to find  $\theta$  when a golf ball is hit with an initial velocity of  $v_0 = 50$  feet per second and lands 77 feet away.

In Exercises 95–98, use the power-reducing formulas to rewrite the expression in terms of the first power of the cosine.

95.  $\sin^6 x$

96.  $\cos^4 x \sin^4 x$

97.  $\cos^4 2x$

98.  $\sin^4 2x$

In Exercises 99–102, use the half-angle formulas to determine the exact values of the sine, cosine, and tangent of the angle.

99.  $105^\circ$

100.  $67^\circ 30'$

101.  $\frac{7\pi}{8}$

102.  $\frac{11\pi}{12}$

In Exercises 103–106, find the exact values of  $\sin(u/2)$ ,  $\cos(u/2)$ , and  $\tan(u/2)$  using the half-angle formulas.

$$103. \sin u = \frac{3}{5}, \quad 0 < u < \frac{\pi}{2}$$

$$104. \tan u = \frac{5}{8}, \quad \pi < u < \frac{3\pi}{2}$$

$$105. \cos u = -\frac{2}{7}, \quad \frac{\pi}{2} < u < \pi$$

$$106. \sec u = -6, \quad \frac{\pi}{2} < u < \pi$$

In Exercises 107 and 108, use the half-angle formulas to simplify the expression.

$$107. -\sqrt{\frac{1 + \cos 10x}{2}} \qquad 108. \frac{\sin 6x}{1 + \cos 6x}$$

**Geometry** In Exercises 109 and 110, a trough for feeding cattle is 4 meters long and its cross sections are isosceles triangles with two equal sides of  $\frac{1}{2}$  meter (see figure). The angle between the equal sides is  $\theta$ .

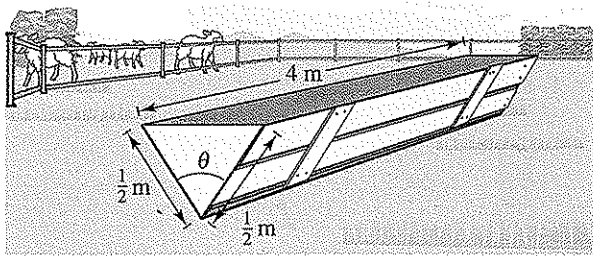

109. Write the trough's volume as a function of  $\theta/2$ .

110. Write the volume of the trough as a function of  $\theta$  and determine the value of  $\theta$  such that the volume is maximum.

In Exercises 111–114, use the product-to-sum formulas to write the product as a sum or difference.

$$111. 6 \sin \frac{\pi}{4} \cos \frac{\pi}{4} \qquad 112. 4 \sin 15^\circ \sin 45^\circ$$

$$113. \sin 3\alpha \sin 2\alpha \qquad 114. \cos 4\theta \sin 6\theta$$

In Exercises 115–118, use the sum-to-product formulas to write the sum or difference as a product.

$$115. \cos 3\theta + \cos 2\theta \qquad 116. \sin 5\theta + \sin 3\theta$$

$$117. \sin\left(x + \frac{\pi}{4}\right) - \sin\left(x - \frac{\pi}{4}\right)$$

$$118. \cos\left(x + \frac{\pi}{6}\right) - \cos\left(x - \frac{\pi}{6}\right)$$

**Harmonic Motion** In Exercises 119–122, a weight is attached to a spring suspended vertically from a ceiling. When a driving force is applied to the system, the weight moves vertically from its equilibrium position. This motion is described by the model

$$y = 1.5 \sin 8t - 0.5 \cos 8t$$

where  $y$  is the distance from equilibrium in feet and  $t$  is the time in seconds.

119. Write the model in the form

$$y = \sqrt{a^2 + b^2} \sin(Bt + C).$$

120. Use a graphing utility to graph the model.

121. Find the amplitude of the oscillations of the weight.

122. Find the frequency of the oscillations of the weight.

### Synthesis

**True or False?** In Exercises 123–126, determine whether the statement is true or false. Justify your answer.

$$123. \text{ If } \frac{\pi}{2} < \theta < \pi, \text{ then } \cos \frac{\theta}{2} < 0.$$

$$124. \sin(x + y) = \sin x + \sin y$$

$$125. 4 \sin(-x) \cos(-x) = -2 \sin 2x$$

$$126. 4 \sin 45^\circ \cos 15^\circ = 1 + \sqrt{3}$$

127. List the reciprocal identities, quotient identities, and Pythagorean identities from memory.

128. Is  $\cos \theta = \sqrt{1 - \sin^2 \theta}$  an identity? Explain.

In Exercises 129 and 130, use the graphs of  $y_1$  and  $y_2$  to determine how to change  $y_2$  to a new function  $y_3$  such that  $y_1 = y_3$ .

$$129. y_1 = \sec^2\left(\frac{\pi}{2} - x\right)$$

$$y_2 = \cot^2 x$$

$$130. y_1 = \frac{\cos 3x}{\cos x}$$

$$y_2 = (2 \sin x)^2$$

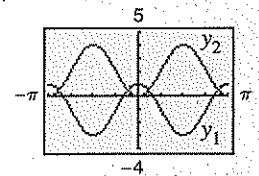
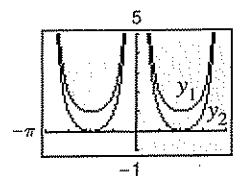

## 5 Chapter Test

Take this test as you would take a test in class. After you are finished, check your work against the answers given in the back of the book.

- If  $\tan \theta = \frac{6}{5}$  and  $\cos \theta < 0$ , use the fundamental identities to evaluate the other five trigonometric functions of  $\theta$ .
- Use the fundamental identities to simplify  $\csc^2 \beta(1 - \cos^2 \beta)$ .
- Factor and simplify  $\frac{\sec^4 x - \tan^4 x}{\sec^2 x + \tan^2 x}$ .
- Add and simplify  $\frac{\cos \theta}{\sin \theta} + \frac{\sin \theta}{\cos \theta}$ .
- Determine the values of  $\theta$ ,  $0 \leq \theta < 2\pi$ , for which  $\tan \theta = -\sqrt{\sec^2 \theta - 1}$  is true.
- Use a graphing utility to graph the functions  $y_1 = \cos x + \sin x \tan x$  and  $y_2 = \sec x$ . Make a conjecture about  $y_1$  and  $y_2$ . Verify your result algebraically.

In Exercises 7–12, verify the identity.

- $\sin \theta \sec \theta = \tan \theta$
- $\sec^2 x \tan^2 x + \sec^2 x = \sec^4 x$
- $\frac{\csc \alpha + \sec \alpha}{\sin \alpha + \cos \alpha} = \cot \alpha + \tan \alpha$
- $\cos\left(x + \frac{\pi}{2}\right) = -\sin x$
- $\cos(\pi - \theta) + \sin\left(\frac{\pi}{2} + \theta\right) = 0$
- $(\sin x + \cos x)^2 = 1 + \sin 2x$
- Find the exact value of  $\tan 105^\circ$ .
- Rewrite  $\sin^4 x \tan^2 x$  in terms of the first power of the cosine.
- Use a half-angle formula to simplify the expression  $\frac{\sin 4\theta}{1 + \cos 4\theta}$ .
- Write  $6 \sin 4\theta \sin 6\theta$  as a sum or difference.
- Write  $\cos 5\theta + \cos 3\theta$  as a product.

In Exercises 18–21, find all solutions of the equation in the interval  $[0, 2\pi)$ .

- $\tan^2 x + \tan x = 0$
- $\sin 2\alpha - \cos \alpha = 0$
- $4 \cos^2 x - 3 = 0$
- $\csc^2 x - \csc x - 2 = 0$
- Use a graphing utility to approximate the solutions of the equation  $5 \cos x - x = 0$  in the interval  $[0, 2\pi)$  accurate to three decimal places.
- Use the figure at the right to find the exact values of  $\sin 2u$ ,  $\cos 2u$ , and  $\tan 2u$ .
- The *index of refraction*  $n$  of a transparent material is the ratio of the speed of light in a vacuum to the speed of light in the material. For the glass triangular prism in the figure at the right,  $n = 1.5$  and  $\alpha = 60^\circ$ . Find the angle  $\theta$  for the glass prism if

$$n = \frac{\sin(\theta/2 + \alpha/2)}{\sin(\theta/2)}$$

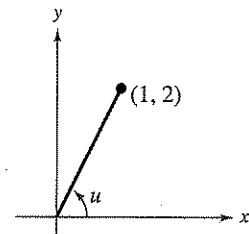

Figure for 23

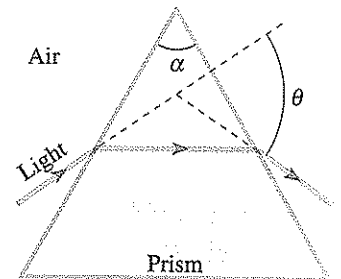

Figure for 24